

Proposal of 3rd DPR under PMAY (BLC), Tripura

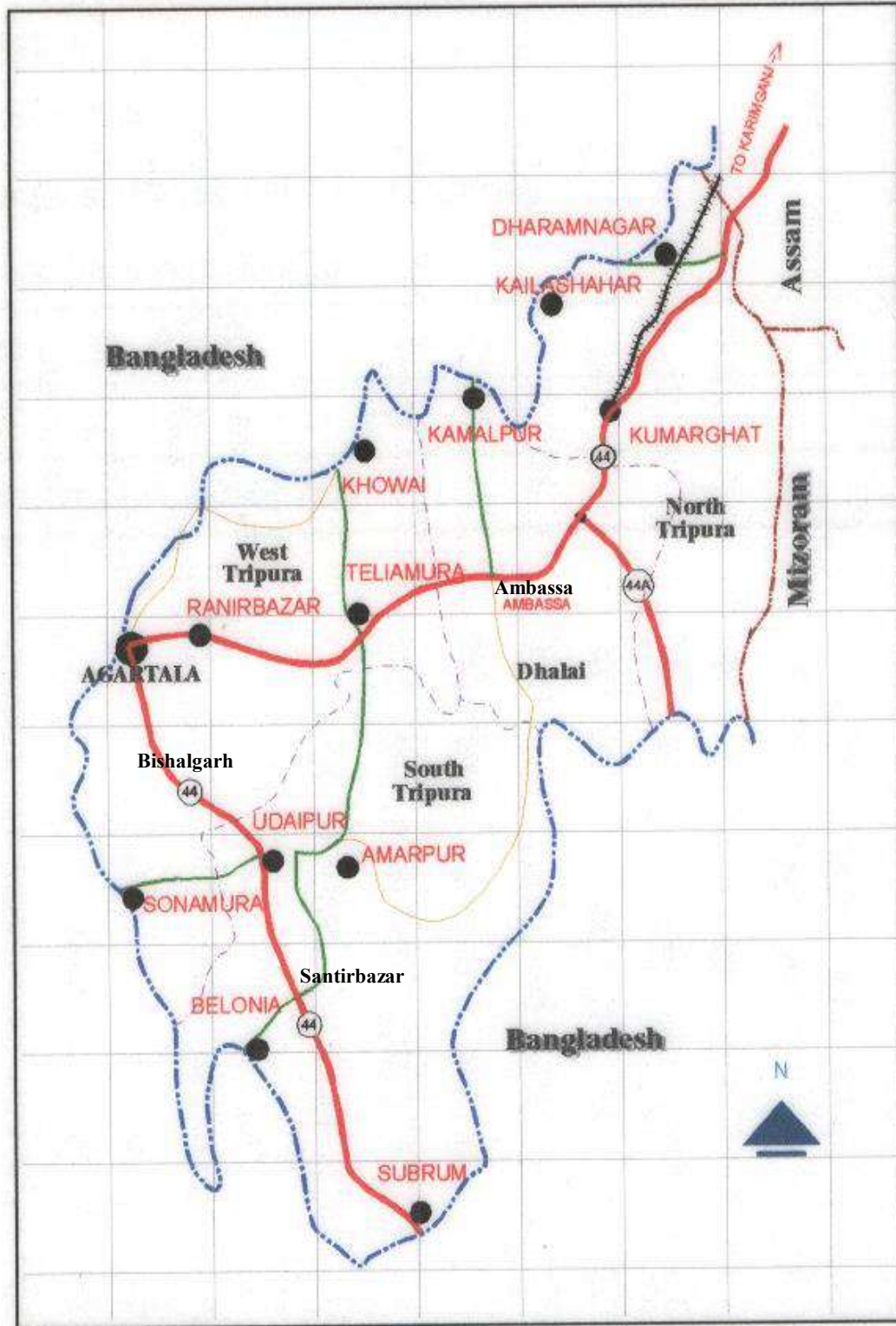

Meeting of CSMC, 26th Sep, 2018

Location of ULBs



Urban Profile of Tripura-



- Urban population: 21% of total Population.
- Statutory towns: 20 (1 Corporation, 13 Municipal Councils & 6 Nagar Panchayats).
- Elections held: Dec 2015.
- Other Schemes: Agartala- ADB, AMRUT & Smart City. All 20 Cities are covered under SBM (U), DAY-NULM, 10% LS, TUEP, FFC Grants, SoT, SDS.
- Problems: Geographical isolation; Transportation bottleneck. Prolonged rainy season. Construction materials have to be brought from outside.
- Supervision : A dedicated Engineering Wing headed by a Chief Engineer.

Achievements so far-



Scheme	Sanction yr	DUs constructed	Remarks.
IHSDP	2007-08 to 2009-10	3115 (in 5 towns)	All completed. 100% occupied. Awards: 2011-12 (for Teliamura), 2012-13 (for Sonamura).
BSUP	2008-09	256 (at Agartala)	All completed. 100% occupied. Awarded in 2010-11.
10% Lumpsum	2010-11	192 (at Radha Nagar)	In progress. 3rd instalment of CA awaited (Rs. 6.59 cr)
10% LS	2013-14	763 (at Dharmanagar)	In progress. 3rd instalment of CA awaited. (Rs.20.02 crore).
RAY	2014-15	3005 (in 4 towns)	In progress. 3rd instalment of CA awaited. (Rs.17.98 crore).
TSGHS	2013-14 & 2015-16	3500 (at 16 ULBs)	State Govt Scheme. All DUs completed.

HOUSING FOR ALL - PLAN OF ACTION

(HFA PoA) for BLC vertical (New Houses)

Sl. No	Name of the vertical	No. of cities /towns	Year	No. of Houses	Project Cost (Rs. In lakhs)	GoI Grant (Rs. In lakhs)	State Share (Rs. In lakhs)	Beneficiary contribution (Rs. In lakhs)	Status
1	BLC (1 st DPR)	20	2016-17	42,896	116418.89	64344.00	7149.05	44925.84	Ongoing
2	BLC (2 nd DPR)	20	2017-18	32,876	89224.81	49314.00	5479.11	34431.69	Ongoing
Total-				75,772	205643.70	113658.00	12628.16	79357.53	

3rd DPR approved by SLSMC-

Sl. No	Name of the vertical	No. of cities /towns	Year	No. of Houses	Project Cost (Rs. In lakhs)	GoI Grant (Rs. In lakhs)	State Share (Rs. In lakhs)	Beneficiary contribution (Rs. In lakhs)	Status
1	BLC (3 rd DPR)	19	2018-19	9778	26537.30	14667.00	1629.60	10240.69	Approved

Progress of BLC (1st DPR)-

- Total units sanctioned – 42,896
- Construction undertaken - 34090 (79%)
 - Foundation Level - 3686
 - Lintel Level - 2770
 - Roof Level - 14958
 - Completed - 12676
 - Yet to start - 8806

Sample houses under PMAY(BLC)-



**ULB Name- Udaipur MC, Beneficiary
Name- Apurba Datta,**



**ULB Name- Sonamura , Beneficiary
Name-Abdul Barek,**

Sample houses under PMAY(BLC)-



**ULB Name- Jirania NP,
Beneficiary Name- Sarna Debbarma,**



**ULB Name- Agartala M. Corp ,
Beneficiary Name-Sarmila Datta Deb,**

2nd DPR

Progress of BLC (2nd DPR)-

- Total units sanctioned – 32,876
- Construction undertaken – 2371
 - Foundation Level - 1790
 - Lintel Level - 417
 - Roof Level - 164

3rd DPR

Demand Assessment -



- Demand Assessment Survey for Housing and sanitation conducted in **January 2016**.
- **2,07,791** urban families were surveyed Door-to-Door (100%).
- Findings:

Total ULBs	Households having	
	Kutcha Houses	Semi-pucca Houses
20	48,512	28,608

- SECC 2011: 23.5% of urban Houses have **grass/ thatch/ bamboo** and another 18.6% have **mud/ unburnt bricks** as predominant wall material.

Process of preparation of DPR-



- Beneficiaries under BLC (New) identified as per Mission Guidelines.
- . There is no duplication of benefits across the verticals.
- All 19 DPRs prepared with complete list of beneficiaries with details including Aadhaar Nos, Beneficiaries' bank accounts no etc.
- Identified beneficiaries & applications received through newspaper advertisement displayed in ward offices. Claims & objections invited through newspaper publicity.

Present proposal – 3rd DPR-PMAY(BLC)



Sl No	No. of Towns (ULBs)	No. of Projects	No. of Dwelling units
1	20	19	9778

Abstract of cost (per BLC house)

Sl	Issue	Cost
1	Estimated cost	Rs. 2, 71,398.00
2	Rate index	SOR- 2011 (R&B) plus 20% cost
3	Method	Directly by the beneficiary
4	Cost of dwelling unit including Sanitary Block	Rs.2, 64,524.00
5	Add anticipated Cost Index 20%	Rs.52, 905.00
6	Total	Rs.3, 17,429.00
7	Less for Contractor's Profit	Rs.46, 031.00
8	Net cost	Rs. 2, 71,398.00

Cost sharing (each unit)-

(Rs lakh)

Total cost of the DU	Central assistance	State's contribution	Beneficiary's contribution
2.71	1.50	0.17	1.04

- The proposal duly **appraised** by SLAC and **approved** by SLSMC

Proposed projects of ULBs- 3rd DPR (New) (in Rs. Lakhs)

City	Nos. of Beneficiaries to be approved	Unit cost Rs. in lakhs	Total Rs. In lakhs	Gol Grant		State Share		Beneficiaries contributions	
				Rate Rs. in lakhs	Amount Rs. In lakhs	Rate Rs. In lakhs	Amount Rs. In lakhs	Rate Rs. In lakhs	Amount Rs. In lakhs
Agartala Municipal Corporation	4224	2.71398	11463.85	1.5	6336	0.16666	703.97	1.04732	4423.88
Amarpur NP	97	2.71398	263.26	1.5	145.5	0.16666	16.17	1.04732	101.59
Ambassa MC	201	2.71398	545.51	1.5	301.5	0.16666	33.50	1.04732	210.51
Bishalgarh MC	436	2.71398	1183.30	1.5	654	0.16666	72.66	1.04732	456.63
Dharmanagar MC	694	2.71398	1883.50	1.5	1041	0.16666	115.66	1.04732	726.84
Jirania NP	61	2.71398	165.55	1.5	91.5	0.16666	10.17	1.04732	63.89
Kailasahar MC	754	2.71398	2046.34	1.5	1131	0.16666	125.66	1.04732	789.68
Kamalpur NP	516	2.71398	1400.41	1.5	774	0.16666	86.00	1.04732	540.42
Khowai MC	274	2.71398	743.63	1.5	411	0.16666	45.66	1.04732	286.97
Kumarghat MC	314	2.71398	852.19	1.5	471	0.16666	52.33	1.04732	328.86
Melagarh MC	328	2.71398	890.19	1.5	492	0.16666	54.66	1.04732	343.52
Mohanpur MC	584	2.71398	1584.96	1.5	876	0.16666	97.33	1.04732	611.63
Panisagar NP	87	2.71398	236.12	1.5	130.5	0.16666	14.50	1.04732	91.12
Ranirbazar MC	224	2.71398	607.93	1.5	336	0.16666	37.33	1.04732	234.60
Sabroom NP	176	2.71398	477.66	1.5	264	0.16666	29.33	1.04732	184.33
Santirbazar MC	295	2.71398	800.62	1.5	442.5	0.16666	49.16	1.04732	308.96
Sonamuura NP	211	2.71398	572.65	1.5	316.5	0.16666	35.17	1.04732	220.98
Teliamura MC	122	2.71398	331.11	1.5	183	0.16666	20.33	1.04732	127.77
Udaipur MC	180	2.71398	488.52	1.5	270	0.16666	30.00	1.04732	188.52
Sub Total	9778		26537.30		14667.00		1629.60		10240.69

Implementation Strategy-

- Construction will be completed in **12 months** by Beneficiaries themselves under supervision and active guidance of Engineering Wing of Department.
- **Geo-tagging** of photographs on completion of each milestone will be monitored by SLNA.
- Mission Director registered on PFMS portal
- Funds will be released by ULB direct (**DBT**) to Beneficiary's Bank account **on milestone basis**
- Low cost & innovative technologies will be tried.
- Civic amenities being provided by convergence

Technical specifications-



- **Unit dimension:** 30 sq m. (5.35 m x 5.55 m)
- **Structural safety:** Depth of foundation kept sufficient for Tripura site condition. Wall thickness kept optimal. RCC lintel of acceptable quality. GCI sheet roofing of sufficient thickness, tied with J or L hook with washer as per safety norms. Steel tubular truss provided for structural stability and reducing fire hazard.
- **Compliance to NBC norms:** The unit has been designed in compliance with IS standards / NBC Guidelines & tested in Tripura condition.
- **Design:** Design and construction of houses to be disaster resilient particularly earthquake proof

**CONSTRUCTION OF DWELLING UNIT
UNDER PRADHAN MANTRI AWAS
YOJANA, HOUSING FOR ALL URBAN**



ELEVATION

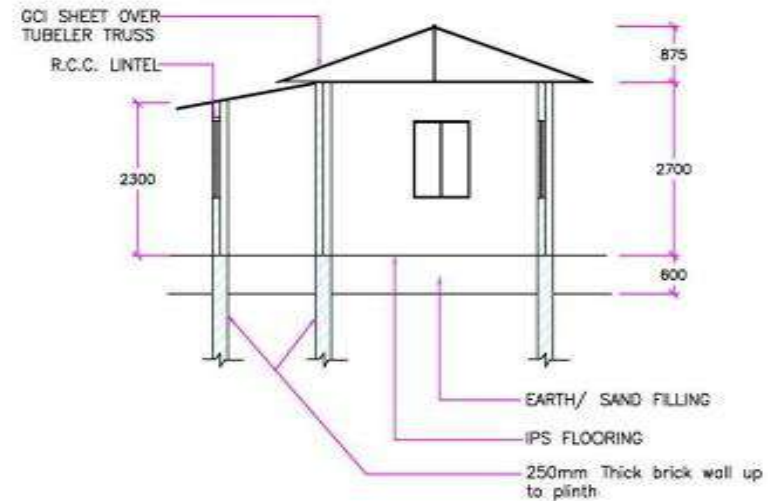

SECTION AT A-B
Basab Dewlling unit.jpg

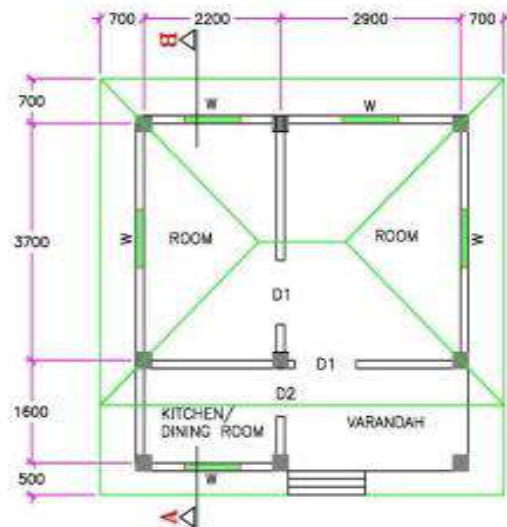

PLAN

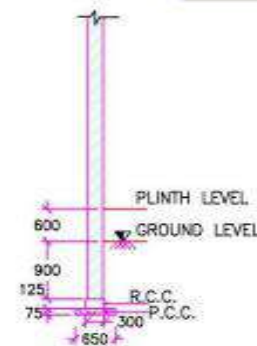

DETAILS OF FOUNDATION

SCHEDULE OF DOORS & WINDOWS*

MKD.	DIMENSION	
	WIDTH	HEIGHT
D1	1000	2100
D2	750	2100
W	900	1200
PLINTH AREA 27Sq. M.		

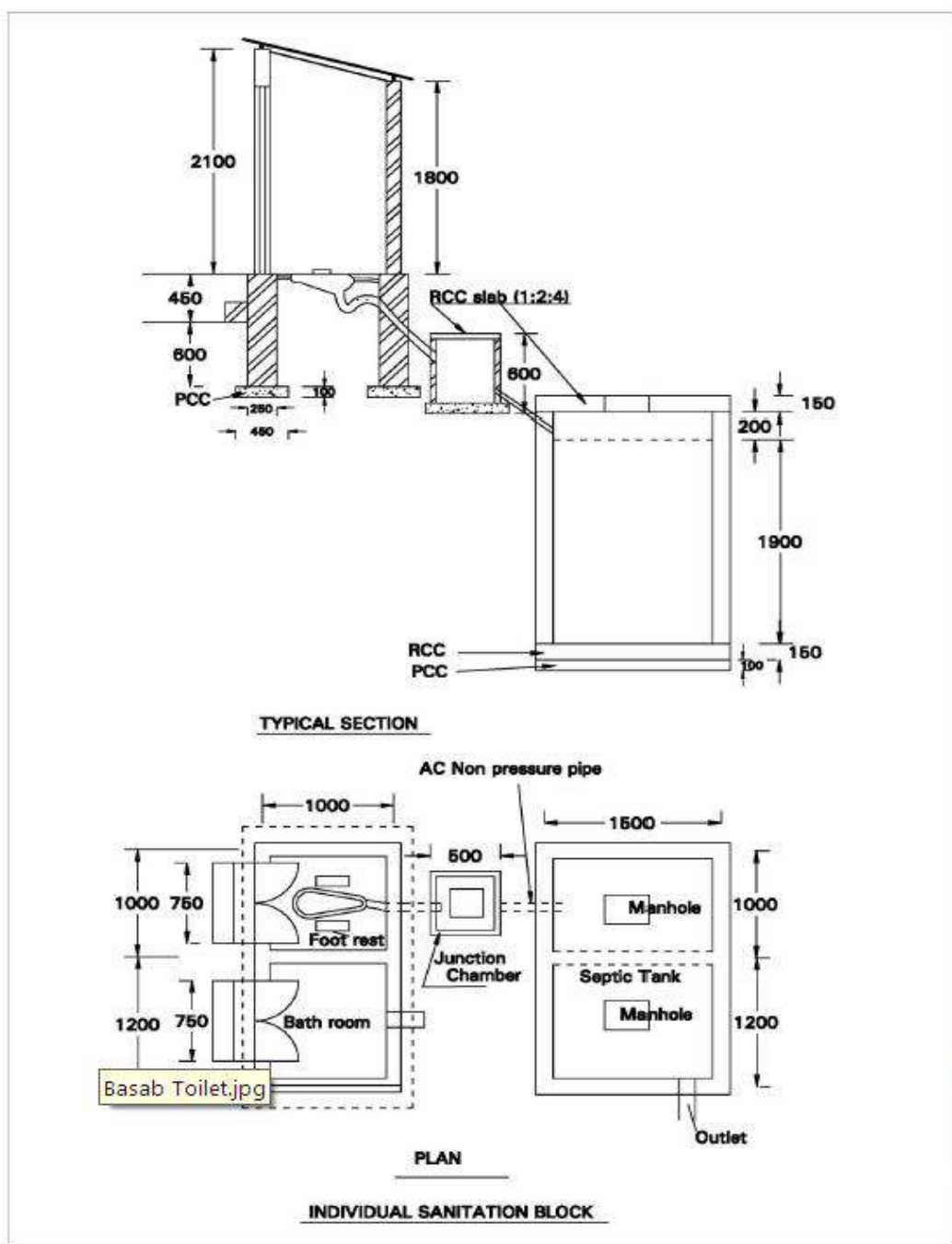

Thank You

• Demonstration Housing Projects (DHPs)-

The State Level Sanctioning & Monitoring Committee has examined the guidelines of Demonstration Housing Project (DHP) and recommended to construct House under DHP at Narasingarh under Agartala Municipal Corporation, Tripura. The proposed DHP will be used for a social cause. The formal proposal along with land details will be prepared by the Dir. of Social Welfare and Education, Tripura and will send to the Mission Directorate (Director, Directorate of Urban development) for sending the same to MoHUA for approval.

Other Verticals:



- **Affordable Houses in Partnership** - Beneficiaries not having land are proposed to be covered under Affordable Houses in Partnership during 2018-19.
- **"In situ" Slum Redevelopment** - 94 Slum pockets identified in Agartala. Development plan being worked out.

Rajiv Awas Yojana (RAY)

(Sanction during 2015-16)



Issue	Status
No. of Projects	4 Nos.
No. of Dwelling Units sanctioned	3005 Nos.
Dwelling Units under progress	3005 Nos.
Dwelling Units Completed	657 Nos.
Total Occupied	657 Nos.
Project cost	Rs.98.80 crore.
Central Share	Rs.77.92 crore
Total ACA Received	Rs. 59.94 crore.
Total UC submitted	Rs. 58.66 crore.
Proposal for 3 rd Installment sent	Rs.17.98 crore.
Expected Date of Completion	March, 2018.

Photograph of Houses constructed under RAY in Khowai Nagar Panchayat



Photograph of Houses constructed under RAY in Sabroom Nagar Panchayat



Photograph of Houses constructed under RAY in Amarpur Nagar Panchayat



Status of Basic Services to Urban Poor - **JNNURM (Sanction during 2007-8)**



Issue	Status
Name of the Project	Basic Services to Urban Poor(BSUP)
No. of Mission Cities	One (Agartala).
Total Project Cost Approved	Rs. 16.73 crore.
Total ACA committed & Released	Rs. 13.46 crore.
Total amount with ULB/IA	Rs. 16.73 crore.
Total Expenditure made by ULB/IA	Rs. 16.73 crore.
Total UC submitted GoI	Rs. 16.73 crore.
Total Dwelling Units Approved (N+U)	256 Dwelling Units.
Total DUs completed and Occupied	256 Dwelling Units.

Vivekananda Awasan: BSUP Project at Agartala



Status of Integrated Housing and Slum Development Programme – JNNURM (Sanction during 2009-10)



Issue	Status
Name of the Project	Integrated Housing and Slum Development Programme (IHSDP)
No. of Projects	5(five) Numbers.
No. of Towns/Cities Covered	5(five) Numbers.
Total Project Cost Approved	43.64 crore.
Total ACA committed and released	38.05 crore.
Total Amount with ULB/IA	43.64 crore.
Total Expenditure made by ULB/IA	43.64 crore.
Total UC submitted	43.64 crore.
Total DUs Approved (N+U)	3115 Numbers.
Total DUs completed and Occupied	3115 Numbers.

Houses under IHSDP Projects-

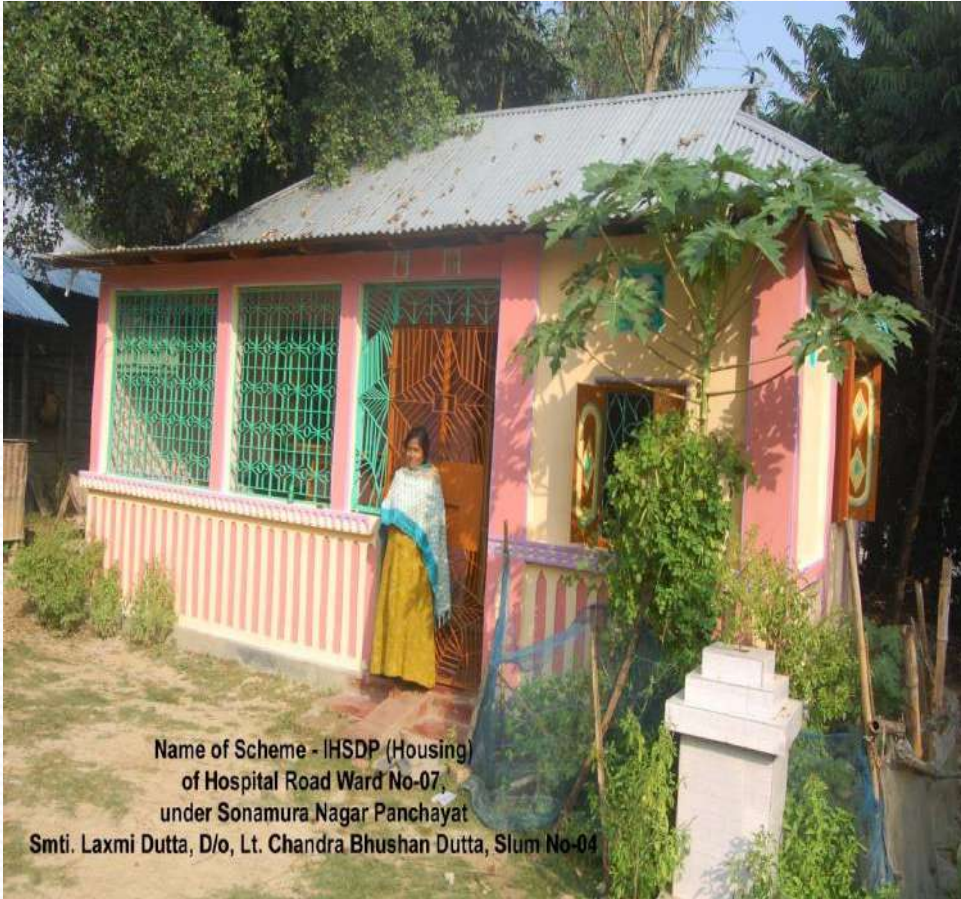

CB and Social Audit Plan



SLSMC has approved CB plan for the year 2018-19 and the same was sent to the MoHUA for approval.

Consolidate budget for CB and SA Plan

Sl. No.	Activity	State Share (In Rs)	Central Share (In Rs)	Total (In Rs)
1	Preparation of PoA	1540000	13860000	15400000
2	Establishment of SLTC	456000	4104000	4560000
3	Establishment of CLTC	1272000	11448000	12720000
4	Trainings and workshops	0	1300000	1300000
5	Exposure Visits	0	800000	800000
6	Documentations/Research	0	500000	500000
7	IEC	0	3500000	3500000
8	TPQM	480000	4320000	4800000
9	Social Audit	0	550000	550000
10	A & OE(Including Geo-tagging)	4040020	36360180	40400000
Total		7788020	76742180	84530000

Houses allotted to vulnerable section



Easing Regulations (Mandatory Reforms)-

- Those families occupying small piece of Govt Khas land with kaccha house are being considered for allotment of 0.04 acre of land as state policy
- Building Rules are under amendment for one time approval of Building Plans of PMAY houses as per the standard prescribed design.

Status of mandatory reform under PMAY-

S I	Conditions (Either through Executive Order/Notification/ Legislation)	Status
1	State shall remove the requirement of separate Non Agricultural (NA) Permission in case land falls in the residential zone earmarked in the Master Plan of city/town.	Achieved. Provision has been incorporated in the TRIPURA Building Rules, 2017 { Rule-4 (4)}.
2	States shall prepare/amend the Master Plans earmarking land for Affordable Housing.	In progress. Tender for Master Planning is in final stage. In terms and conditions of the tender earmarking land for Affordable Housing has been included.
3	State shall put in place a single-window time bound clearance system for layout approvals and building permissions.	Achieved Single-window-time bound clearance system for layout approvals and building permissions is in place

Mandatory reform-continues

Sl	Conditions (Either through Executive Order/Notification/ Legislation)	Status
4	States shall adopt pre-approved building permission and layout approval system for EWS/LIG housing or exempt approval below certain built up area /plot area.	Achieved. Provision has been incorporated in the Tripura Building Rules, 2017 {Rule-54(10)}
5	States shall legislate or amend existing rent laws on the lines of the Model Tenancy Act circulated by the First Party.	Not yet finalized by the Government of India.
6	States shall provide additional Floor Area Ratio (FAR)/Floor Space Index (FSI)/ Transferable Development Rights (TDR) and relax density norms, for slum redevelopment and low cost housing	Achieved. The provision for relaxing Rules in case to case basis has been incorporated in the Tripura Building Rules, 2017 {Rule-3}

ADHERENCE TO THE CONDITIONS-



Sl. No	Condition	Adherence
1	All proposed projects are on litigation free land?	Yes, under BLC each beneficiary have their own land.
2	Status of Demand Survey, and timeline for completion, if not completed yet	Completed for BLC.
3	If Demand Survey is complete, has the state shared the list of CLSS beneficiaries to the Ministry?	List of BLC beneficiaries shared. CLSS under preparation
4	whether beneficiaries have been identified and listed in the DPR in conformity with SECC data?	Yes
5	Timelines for Project Completion (Months) For all BLC Projects timelines must be within 2 years of release of funds from Government of India.	Yes, 12 months for BLC projects subject to continuous flow of fund .
6	Status of Physical Infrastructure like drainage, road, street lighting, solid waste management, etc? If not available, whether the provision has been made in the project on this account?	Project is linked with existing infrastructure . In Agartala infrastructure being augmented by ADB, AMRUT and SMART city projects.
7	Whether the convergence with other centrally assisted programmes for provision of Infrastructure?	Yes, in some ULBs with Swachh Bharat Mission and AMRUT.

Sl. No	Condition	Adherence
8	Whether connection to Electricity & Water Supply has been planned under the project? The project shall not be considered complete unless them Houses are provided with Electricity & Water Supply.	Yes, all the dwelling units will be provided with individual toilets, water connection and electricity.
9	Status of Social Infrastructure?	Existing in the proposed areas.
10	Beneficiary details compiled as per Annexure 4B?	Yes.
11	Project Proposals submitted as per Annexure 7C?	Yes.
12	Whether the DPR contains the Financial details/Funding pattern of the Project?	Yes.
13	Details of the proposed ownership of houses – in favor of Women/Joint ownership	Yes.
14	Any other innovative approach taken by the state in proposed projects?	Award for best quality house.
15	Whether the Project Proposals are consistent and adhere to Guidelines in all aspects?	Yes.

