



AWAAS- Odisha Urban Housing Mission

Projects for approval under Beneficiary Led Vertical (BLC) of PMAY

Date: 22-07-2016



State's Initiatives towards Housing

Key interventions in Legislative/ Regulatory Reforms

1. **Establishment of AWAAS- Odisha Urban Housing Mission**
2. **Establishment of District Urban Housing Societies in 30 +1 Districts.**
3. **CDP Land Implementation Policy (CLIP), 2015**
4. **Policy on Housing for All in urban areas of Odisha, 2015**
5. **ODA Amendment Act, 2015**
6. **Odisha Apartment Ownership Act**
7. **Odisha Street Vendors Rules & scheme, 2015-notified**
8. **TDR Rules notified**
9. **Policy on Rehabilitation of slum / project evicted people – notified**



District Urban Housing Society

- The government has created **Odisha Urban Housing Mission (AWAAS)** understanding the need of an institutional arrangement at the state level to focus only on **Urban Housing**.
- A similar arrangement is created at the district level
- Such a setup at district level is setup to ensure accountability to the state government along with capability of implementation and monitoring at the district level.

Formation and composition of the District Urban Housing Society



- **The District Urban Housing Society (DUHS) is registered separately under Society Registration Act XXI, 1860.**
- **the DUHS is affiliated with the Odisha Urban Housing Mission for better coordination, supervision, uniformity of procedures, guidance and cross learning.**
- **The DUHS has a General Body as well as an Executive Committee. Concerned Collector and District Magistrate will chair both the governing body and executive body of respective DUHS.**
- **Office of PD DUDA will maintain the documents and files relating to the society. All members of the Society shall be accountable to the Collector and Chairman of the Society.**





RENTAL HOUSING FOR CONSTRUCTION WORKERS

RENTAL HOUSING FOR MIGRANT LABOURERS

Problem Area

These seasonal labourers are vulnerable because

- They are from unorganized sector
- They are not permanent residents of the city
- Excluded from various initiatives taken for the urban poor

Thus they are living in “***deprived living conditions***”

Initiative

- To provide innovative solution for Rental Housing provision for these construction labourer.
- This is a ***joint initiative of Govt of Odisha (H&UD dept) and Construction Worker Welfare Board to provide shelter to this deprived group.***

Conceptual Idea

- **Target areas** : in the first phase all 5 Municipal Corporations, Puri, Angul, Balasore, Jharsuguda, Talcher, Paradeep, Rayagada
- Location of Rental Housing complex shall be ***in proximity to ongoing and perspective construction areas.***
- Each rental housing complex would ***cater to a population between 50 to 100 through dormitory system for bachelors and single unit for workers with family.***
- The proposed rental housing complex shall be ***weatherproof permanent structure with vertical expansion provision .***
- ***Community level basic facilities like sanitation, drinking water, electricity, connectivity, Common Kitchen Dinning Space, open space for socialisation etc.***
- ***Modular form of design flexible for future expansion.***
- ***A management unit will be formed for each cluster of rental housing complex to take care of day to day management and maintenance of the complex.***
- ***Cost of rental housing complex: 50 beds arrangement would tentatively be around 50 lakhs and for 100 bedded around 1 crore.***
- ***Implementing partner: CPSUs like HPL, NBCC, Bridges & Roof. etc (in the process of finalization)***

Rental Housing Designs...

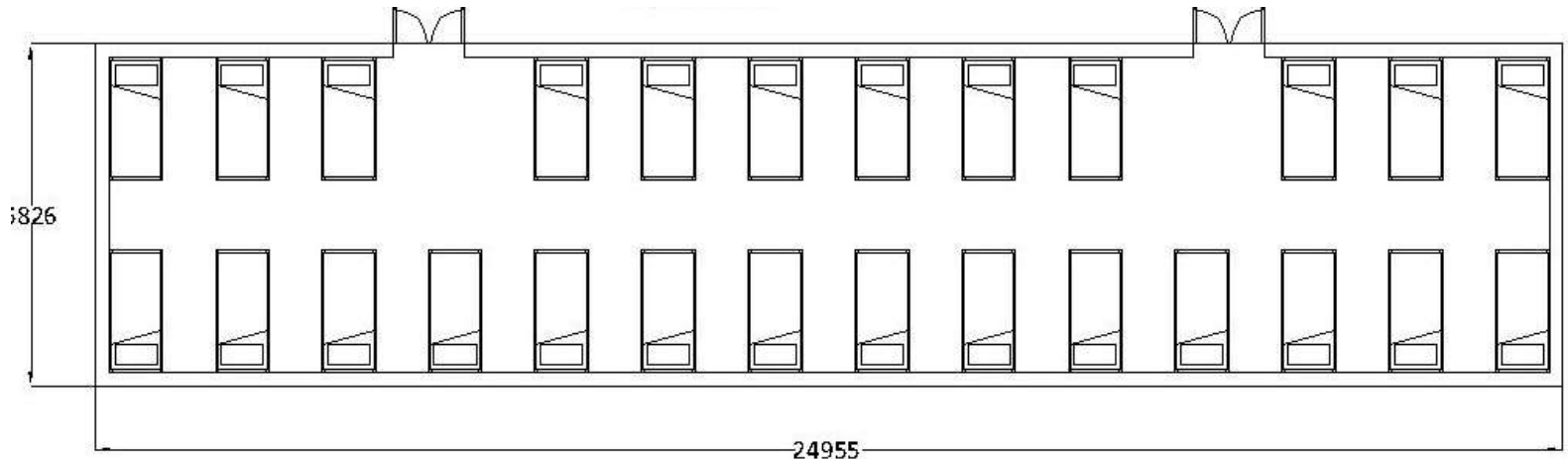

DORMITORY 100 BEDS

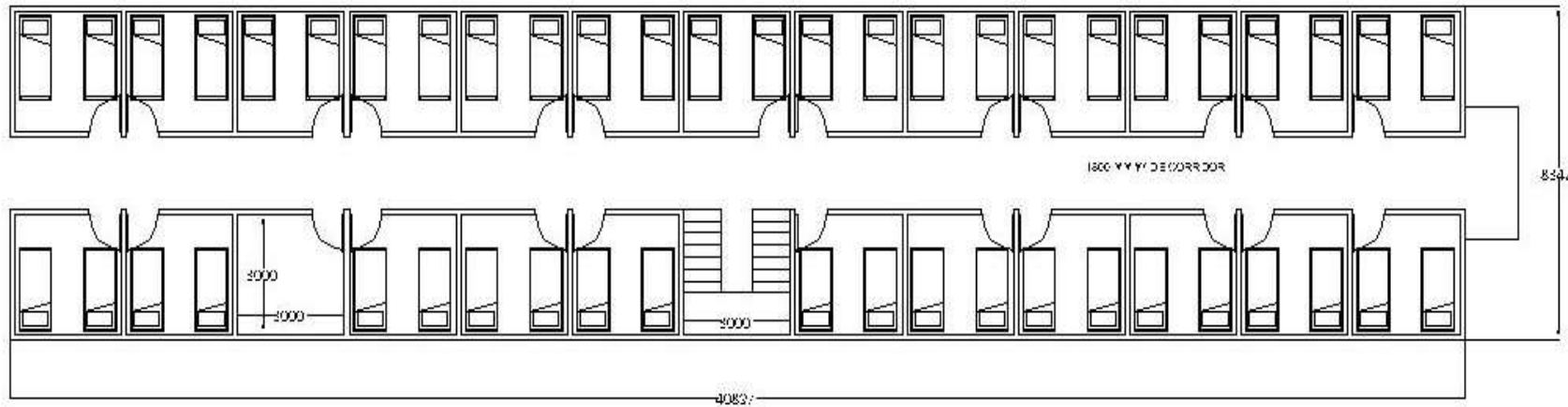

SINGLE UNIT OPTION -I (50 UNITS)

Single unit option -2 front view





GROUND FLOOR

(112 BEDS)



FIRST FLOOR
(96 BEDS)

Dormitory internal view with bunk beds



Dormitory internal view with bunk beds



SINGLE UNIT OPTION-2 (58 UNITS)

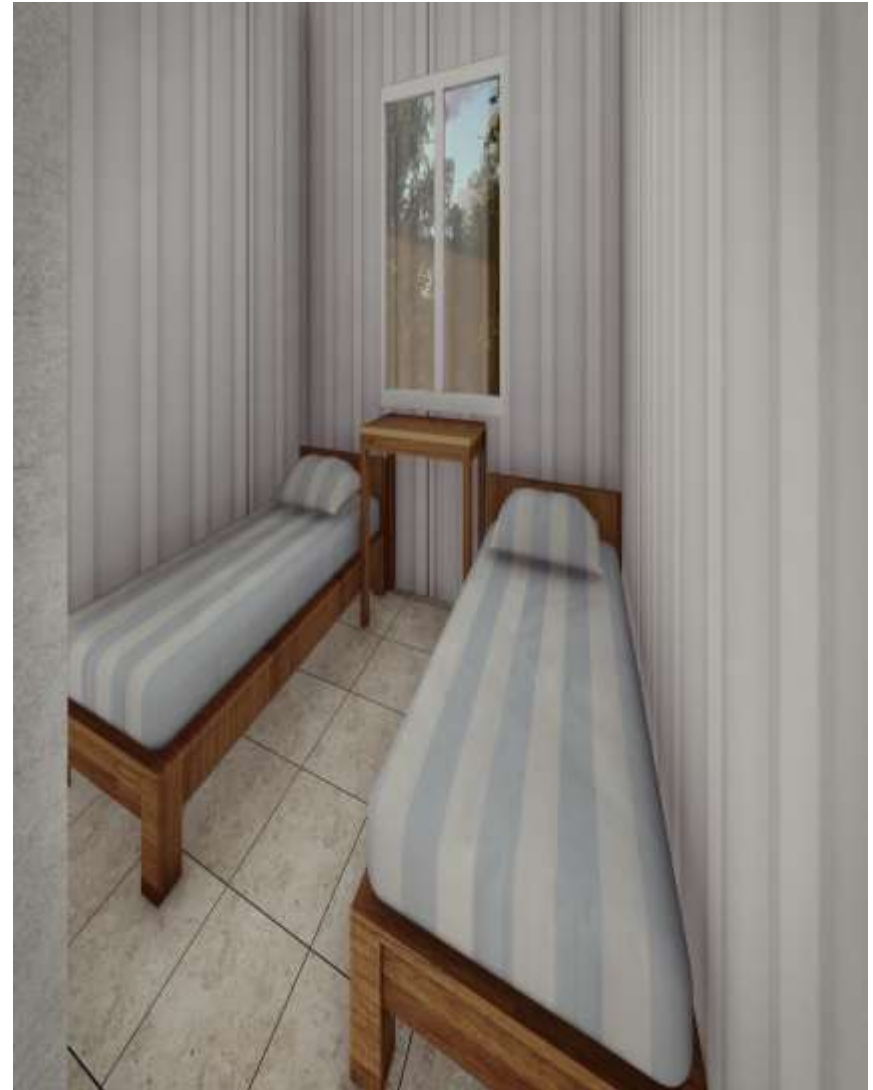
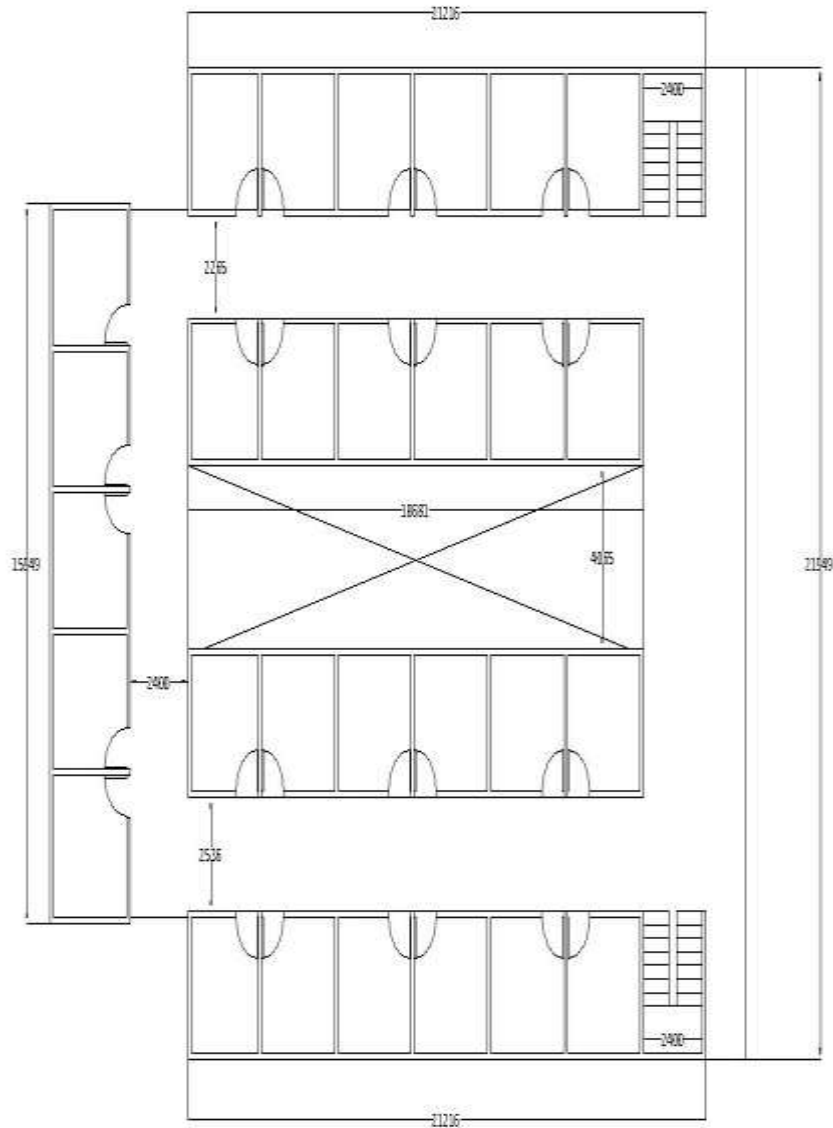

Single unit Internal View

Kitchen block



Toilet blocks





Direct Benefit Transfer (DBT) APP

Proposed System of Direct Benefit Transfer (DBT)

Pradhan Mantri Awas Yojana (Housing for All (Urban) – Process Flow (Beneficiary-led Individual House)

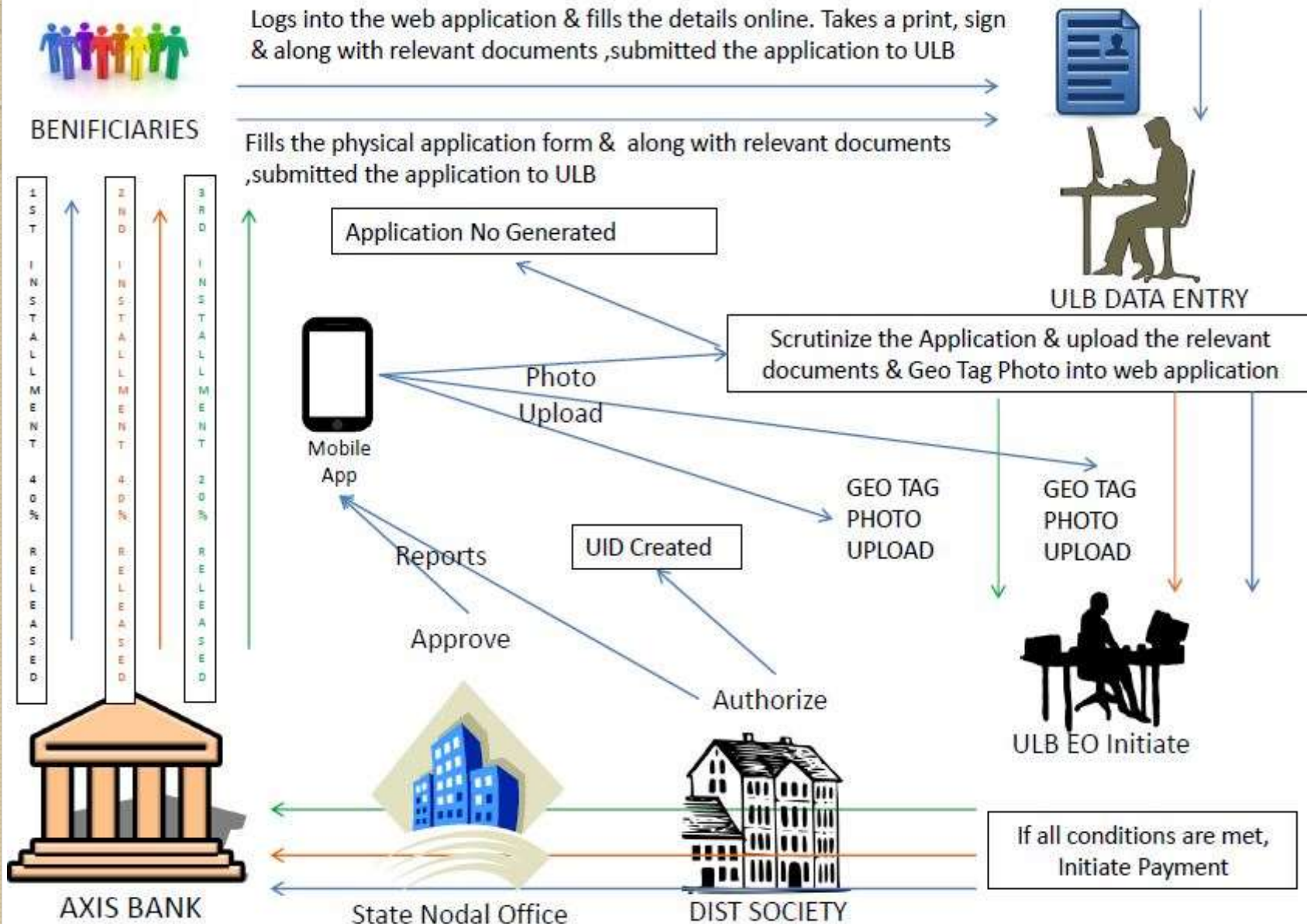

Process Flow

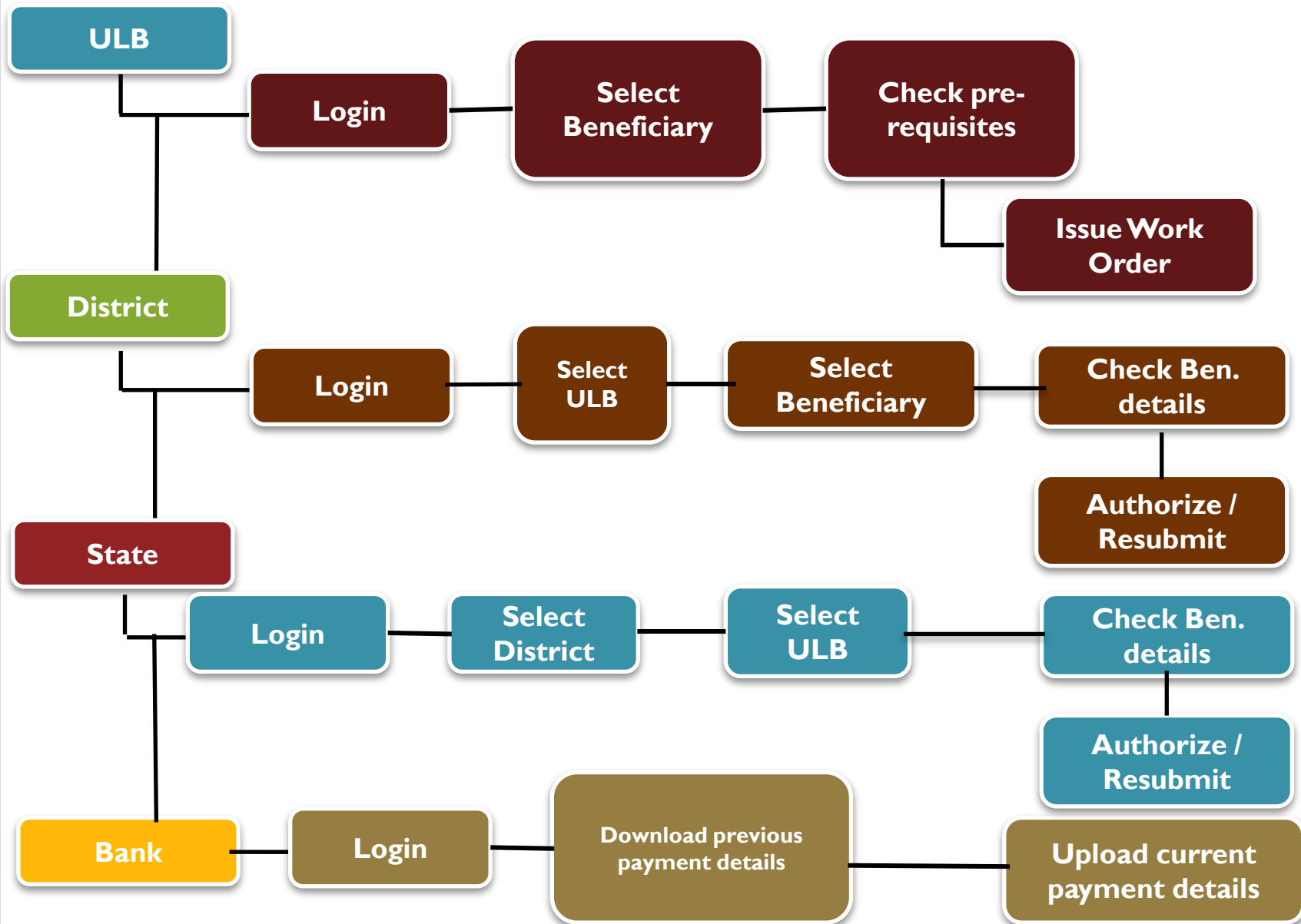

Snapshots of the Application

Work Order

P.L

R.L

R.C

Completion



LOGIN

ULB

DISTRICT

STATE

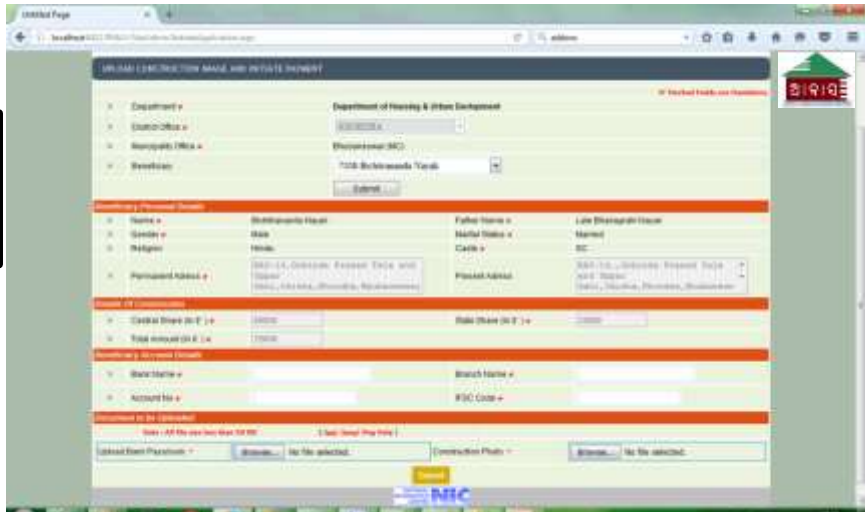

BENEFICIARY

State



APPROVAL FOR FUND TRANSFER

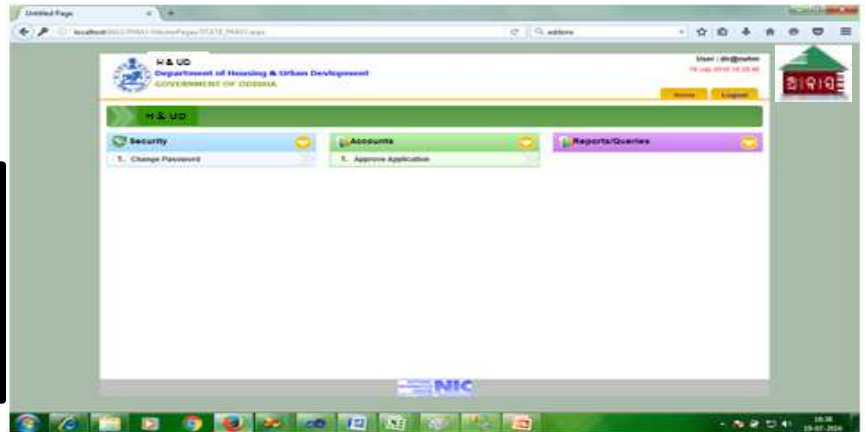

FUND TRANSFER PROCESSED

Status of PMAY in a Snapshot

- **5 mandatory reforms achieved out of 6.**
- **4 DPRs under AHP model approved by MoHUPA in Bhubaneswar**
- **2 in-situ development projects of Bhubaneswar and Rourkela approved.**
- **2 State level workshop and 4 regional level workshops conducted on PMAY.**
- **Demand survey under progress will be completed by end of August,2016**
- **State will contribute Rs 50,000/- per beneficiary under BLC vertical.**
- **ASCI, Hyderabad is nominated for establishment of SLTC & CLTCs.**

Status of Mandatory reforms under Pradhan Mantri Awas Yojana

Sl No	Conditions (Either through Executive Order/Notification/ Legislation)	Proposed timeline as per MoA	Present Status	Achieved on
1	State shall remove the requirement of separate Non Agricultural (NA) Permission in case land falls in the residential zone earmarked in the Master Plan of city/town.	2015-17	Odisha Development Authorities Amendment Act, 2015 has the provisions for Removal of dual control over land use; 20% land reservations in Master Plans for Affordable Housing ;	Achieved on Nov 2,2015
2	States shall prepare/amend the Master Plans earmarking land for Affordable Housing.	2015-17	Common Application Form (CAF) for Fast Track Single Window Approvals ;	
3	State shall put in place a single-window-time bound clearance system for layout approvals and building permissions.	2015-16	Land and building plan approval is covered under RTPSA which mandates service delivery within 60 Days.	
4	States shall adopt pre-approved building permission and layout approval system for EWS/LIG housing or exempt approval below certain built up area /plot area.	2015-17	Presently under Building Plan regulation 2008 within 100 Sq.mtr exempted	
5	States shall legislate or amend existing rent laws on the lines of the Model Tenancy Act circulated by the First Party.	2015-17	Under Process.	
6	States shall provide additional Floor Area Ratio (FAR)/Floor Space Index (FSI)/ Transferable Development Rights (TDR) and relax density norms, for slum redevelopment and low cost housing	2015-16	Notification No. HUD-HU-SCH-0002-2015-20719 /dated 14-08-2015; As per Policy for Housing for All in Urban Area, Odisha 2015, additional FAR and TDR are provided for for slum redevelopment and low cost housing	Achieved on 14-08-2015.

Status of Demand Survey

SI No	District	Name of the City	Total Household	Total Housing Shortage
1	Khurda	Bhubaneswar	2,11,609	68,702
2	Sundargarh	Rourkela	1,05,262	40,103
3	Puri	Puri	42,740	34,461
4	Cuttack	Cuttack	1,05,223	24,240
5	Jagatsinghpur	Paradeep	18,579	18,846
6	Bhadrak	Bhadrak	19,763	17,679
7	Sambalpur	Sambalpur	54,142	17,454
8	Jharsuguda	Jharsuguda	19,414	16,161
9	Kalahandi	Bhawanipatna	14,588	12,933
10	Mayurbhanj	Baripada	22,976	12,556
11	Jharsuguda	Brajarajnagar	17,322	12,066
12	Keonjhar	Barbil	13,418	11,341
13	Bargarh	Bargarh	16,429	10,991
14	Ganjam	Berhampur	64,646	10,719
15	Balasore	Balasore	23,741	10,715
16	Bhadrak	Basudevpur	7,056	10,115
17	Kendrapara	Patamundai	7,344	8,077
18	Balasore	Soro	6,638	7,613
19	Keonjhar	Keonjhargarh	11,802	7,197
20	Sundargarh	Biramitrapur	6,810	6,961

Cont...

Status of Demand Survey

Sl No	District	Name of the City	Total Household	Total Housing Shortage
21	Sundargarh	Rajgangpur	10,503	6,475
22	Bolangir	Titilagarh	6,862	6,422
23	Jajpur	Jajpur	7,908	6,245
24	Keonjhar	Joda	8,335	6,207
25	Jajpur	Vyasnagar	9,853	6,133
26	Dhenkanal	Dhenkanal	13,527	6,050
27	Nabarangapur	Umerkote	6,255	5,667
28	Sundargarh	Sundargarh	9,417	5,663
29	Raygada	Raygada	14,878	5,274
30	Deogarh	Deogarh	4,877	5,134
31	Cuttack	Choudwar	8,520	4,818
32	Malkanagiri	Malkanagiri	6,520	4,754
33	Jagatsinghpur	Jagatsinghpur	6,799	4,604
34	Balasore	Jaleswar	5,362	4,408
35	Mayurbhanj	Rairangapur	5,160	4,034
36	Pulbani	Phulbani	7,829	3,928
37	Angul	Talcher	8,145	3,735
38	Angul	Angul	8,325	3,320
39	Gajapati	Parlakhemundi	9,518	2,827
40	Koraput	Sunabeda	12,151	2,334
			9,60,246	4,56,962

Status of Demand Survey

ULB wise analysis on Housing Demand

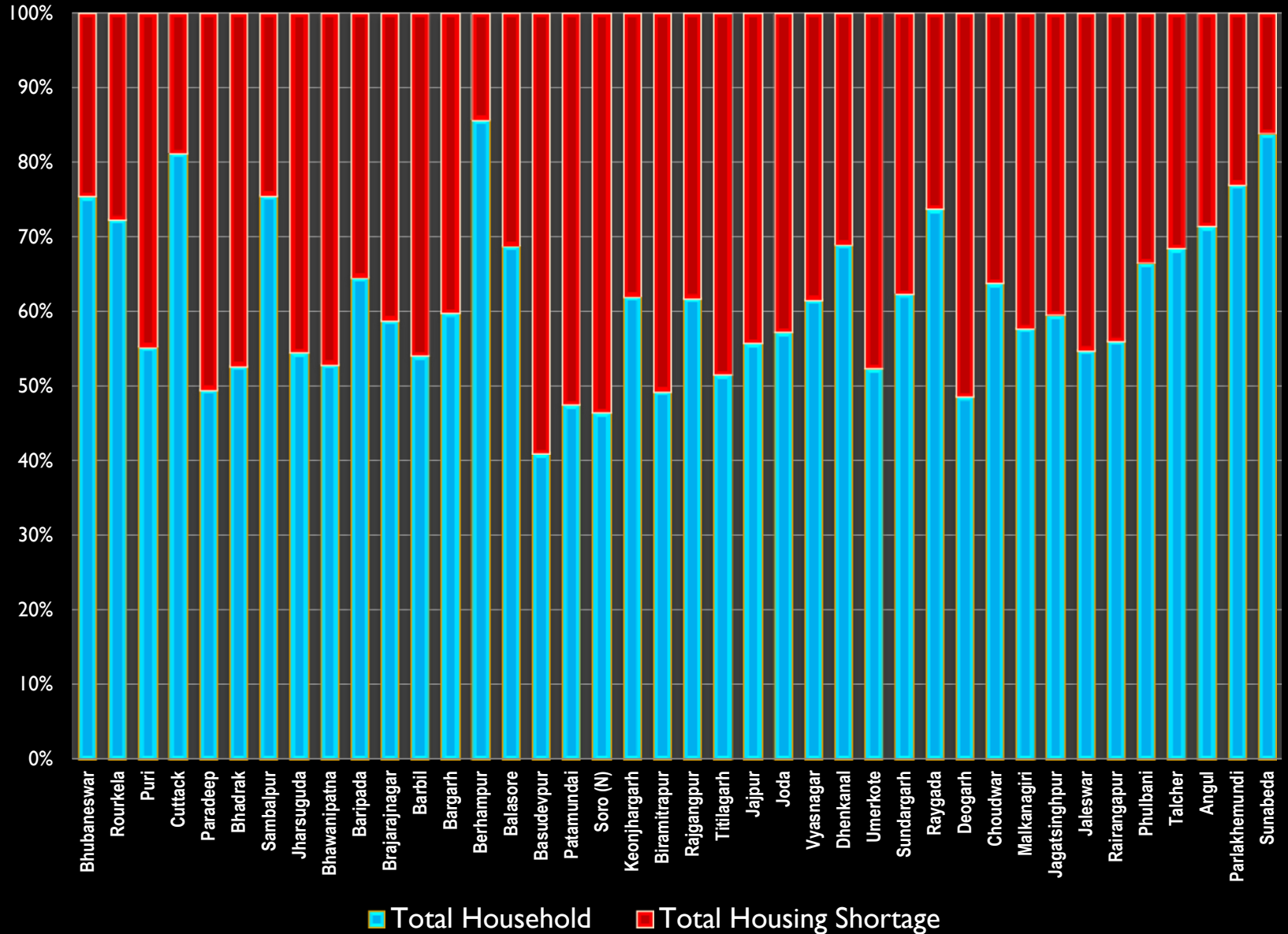

DEMAND SURVEY & SOCIAL CONSULTATION



FEW SNAPSHOTS - AWARENESS GENERATION & SOCIAL CONSULTATION



State Level Workshops



IMPLEMENTATION OF HOUSING FOR ALL, PMAY STRESSED

Express News Service

Bhubaneswar: With an objective to sensitise stakeholders of the ongoing housing programmes, a two-day orientation workshop organised by the State Urban Development Authority concluded here on Saturday.

Representatives of five municipal corporations and 50 municipalities attended the workshop which focused on Odisha Housing for All scheme and the Pradhan Mantri Awas Yojana (PMAY). While the Central Government will be providing subsidy of ₹1.5 lakh per beneficiary to construct their houses under PMAY, the major highlight of the event was beneficiary-led construction which is the sixth model enlisted in the

Odisha Housing for All Policy. The facility will support construction of houses upto 30 sqm of carpet area with basic civic infrastructure. Slum redevelopment projects and affordable housing projects would work in tandem to provide basic civic infrastructure like water, sanitation, sewerage, road and electricity to the beneficiaries.

ULBs will ensure that individual houses under credit linked interest subsidy and beneficiary-led construction should have provision for these basic civic services. Proper community mobilisation and creating awareness among people to reap maximum benefit from the beneficiary-led construction facility and developing bank linkages were also discussed.

ବିଜ୍ଞାପିତ ଅସ୍ଥଳ ପରିଷଦ କାର୍ଯ୍ୟାଳୟ, ଦଶପଲ୍ଲୀ
ଜିଲ୍ଲା-ନୟାଗଡ଼
 ପତ୍ର ନଂ. ୨୧୩(୧) **ବିଜ୍ଞାପନ** ଡା.୧୦.୦୬.୧୬

ଏହାପାଇଁ ଦଶପଲ୍ଲୀ ବିଜ୍ଞାପିତ ଅସ୍ଥଳ ପରିଷଦରେ ଦାବି କରୁଥିବା ଉପଯୋଗୀଙ୍କ ଅନୁମତି ନିମନ୍ତେ ଉପରୋକ୍ତ ଶିଳ୍ପୀମାନଙ୍କ ସେ ପରାମର୍ଶ ନ ଥିବା ଦେଖିବାକୁ ନିଜର ସରକାରୀ ଘର ବାଡ଼ି ସମ୍ପୂର୍ଣ୍ଣ ପ୍ରାୟତ୍ନ ସହ ଯୋଜନା ନାମରେ ନାମ ଦାଖଲ କରି ଉପରୋକ୍ତ ଅନୁମତି ଯୋଗାଇଦେବା ନିମନ୍ତେ ସରକାରଙ୍କୁ ଅନୁରୋଧ କରାଯାଉଛି । ଏହିନିମନ୍ତେ ପ୍ରଧାନମନ୍ତ୍ରୀ ଆବାସ ଯୋଜନା ନାମରେ ପ୍ରତିବନ୍ଧକ ଯୋଗାଣ ବିଧିବଦ୍ଧିତ ହିସାବଦାଖାତ୍ର ଟ. ୧,୫୦,୦୦୦/- (ଏକ ଲକ୍ଷ ପଚାଶ ହଜାର) ଶହଟଙ୍କା ସରକାରଙ୍କ ନାମରେ ଟ. ୫୦,୦୦୦ (ପଚାଶ ହଜାର) ଟଙ୍କାର ସରକାରୀ ସରକାରଙ୍କ ପକ୍ଷରୁ ଯୋଗାଇ ଦିଆଯିବ । ନିମ୍ନଲିଖିତ ଯୋଗାଣ ବିଧିବଦ୍ଧିତ ଯୋଜନା ଅନୁମତି ଯୋଗାଇ ଦେବା ସରକାରଙ୍କ ଦ୍ଵାରା ଭାରତୀୟ ସରକାରଙ୍କୁ ଦିଆଯିବ ।

ପଞ୍ଜୀକଳା

୧. ହିସାବଦାଖାତ୍ର ପରିଷଦ ପରିଷଦ ଦ୍ଵାରା, ଆ ୫ ସେକ୍ଟରର ଅଧିକାଂଶିତ ପିଲାଙ୍କୁ ଦୁଇଟିଟି ।
୨. ପରିଷଦର ପୁଞ୍ଜୀ ନାମରେ ଫି ଦାଖଲ କରି ସରକାରଙ୍କୁ ଦିଆଯିବ ।
୩. ଅନୁମତିପ୍ରାପ୍ତ ହେବା ପରେ ଉପରୋକ୍ତ ନାମରେ ଅନୁମତି ୪୦ ବର୍ଷିକରୁ ଉପରକୁ ବ୍ୟବହାରଯୋଗ୍ୟ କରି ଥିବା ଅବଶ୍ୟକ ।
୪. ଗରୀବ ବର୍ଣ୍ଣିତ ଗୋଟିଏଟି ଟ. ୧,୮୦,୦୦୦/- (ଏକ ଲକ୍ଷ ଅଠାଶ ହଜାର) ଟଙ୍କାକୁ ଚାହୁଁ ଯୋଗ୍ୟ ।
୫. ଅନୁମତିପ୍ରାପ୍ତ ହେବା ପରେ ପରିଷଦର ଶୋଭା ସମୟ ସ୍ଵତନ୍ତ୍ର ଭାବରେ ଯୋଜନାରେ ହିସାବଦାଖାତ୍ର ଯୋଗାଇ ଦିଆଯିବ ।
୬. ସରକାରୀ ଘର ବାଡ଼ିବାର ପିଲାଙ୍କୁ ପିଲା ସମୟରେ ବିଶିଷ୍ଟତା ପରିଷଦ ପାର୍ଟି ସମ୍ମାନ ଦିଆଯିବ ।
୭. ଅନୁମତିପ୍ରାପ୍ତ ହେବା ପରେ ପରିଷଦର ଶୋଭା ସମୟ ନାମରେ ଉପରୋକ୍ତ ଶୋଭା ସମୟରେ ଉପରୋକ୍ତ ନ ଥିବ ।
୮. ସ୍ଵତନ୍ତ୍ର ଭାବରେ ଦାଖଲକରାଯାଇ (Work Order) ପରାମର୍ଶ ଦେଲେ ହିସାବଦାଖାତ୍ର ଗାର୍ଡ଼ ନିମ୍ନ ଲିଖିତ ପରାମର୍ଶରେ ଅନୁମତି ଟ. ୬୦,୦୦୦/- ଟଙ୍କା ଥିବା ଅବଶ୍ୟକ ।

ଗୋଟିଏ ଚାକିରୀକୁ ଥିବା ଆବଶ୍ୟକ ଭାଗରାଜ

୧. ପିଲାଙ୍କୁ ଅଧିକାଂଶରେ ଥିବା ଚାକିରୀର ଅଧିକାର ନାହିଁ ।
୨. ଚାକିରୀର ଅଧିକାର ନାହିଁ ।
୩. ଚାକିରୀ ଗାର୍ଡ଼ : ଗୋଟିଏ ଚାକିରୀର ପତ୍ରର ଅଧିକାର ନାହିଁ ।
୪. ପିଲାଙ୍କୁ ଉପରୋକ୍ତ ସରକାରଙ୍କୁ ୨ (ଦୁଇ) ଟିକା ଉପାଦାନ ଥିବା ।
୫. ଚାକିରୀ ନାମରେ ଅଧିକାର ନାହିଁ ।
୬. ଚାକିରୀ ନାମରେ ଅଧିକାର ନାହିଁ ।

ଟି.ଡି. :- ଗୋଟିଏ ଚାକିରୀର ଚାକିରୀ ଗାର୍ଡ଼ ଚାକିରୀର ଉପ ଯୋଗାଇ ଦିଆଯିବ । ଉପରୋକ୍ତ ଚାକିରୀ ଗାର୍ଡ଼ ନାମରେ ଚାକିରୀ ୧୫ ଟିକା ନାମରେ ଚାକିରୀର ଚାକିରୀର ଅଧିକାର ନାହିଁ ।

ସ୍ଵା-
 ୧୦.୬.୧୬
 ପରିଷଦର ଅଧିକାରୀ,
 ବିଜ୍ଞାପିତ ଅସ୍ଥଳ ପରିଷଦ, ଦଶପଲ୍ଲୀ

THE GRAND NEW
INDIAN EXPRESS

Sun, 17 January 2016
 epaper.newindianexpress



Stage -I: Identification of Beneficiaries

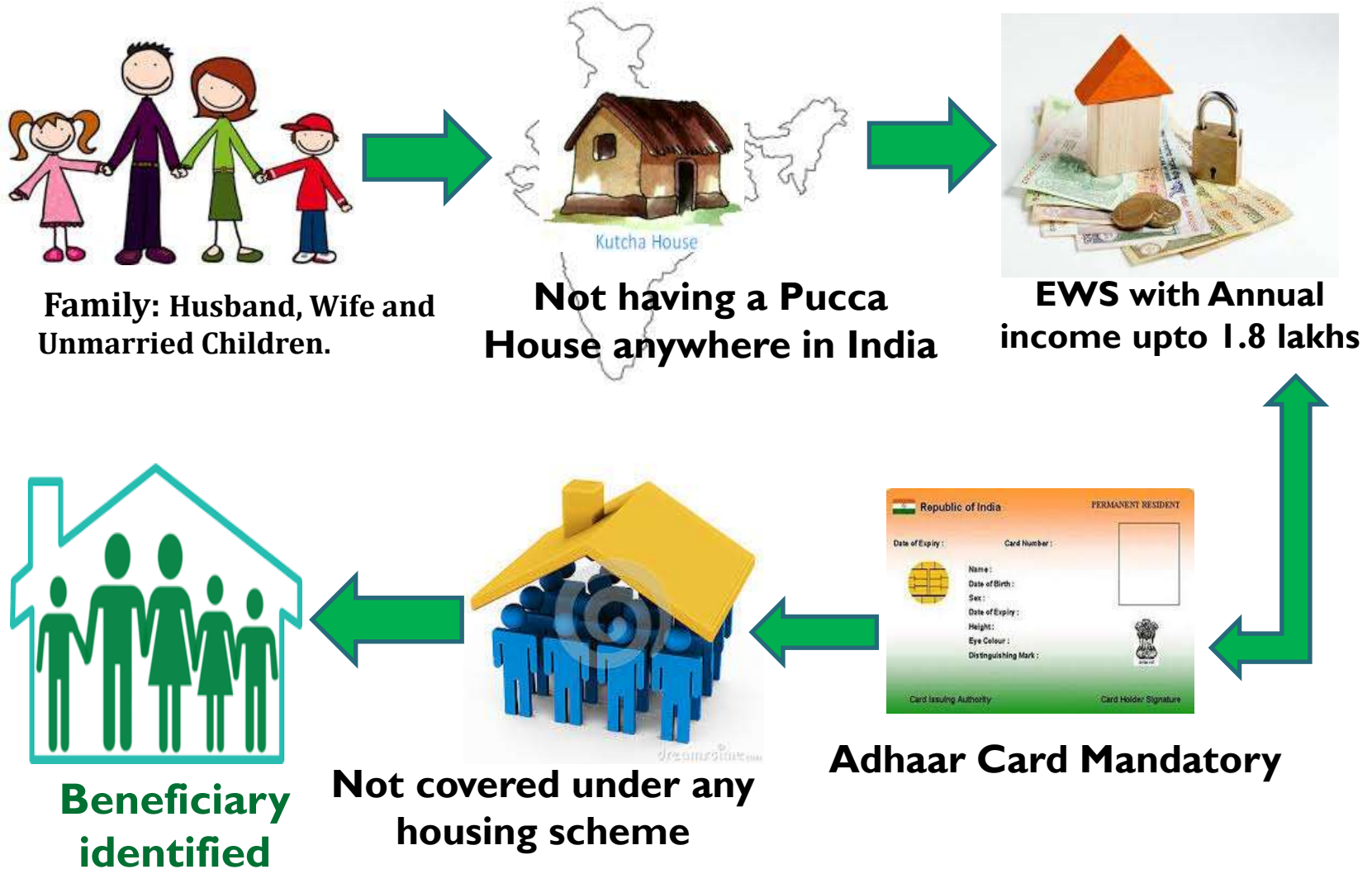

Stage -II: Verification of Beneficiaries



Kutchra House in own land, As per SECC Data/Physical verification by ULBs



Income certificate from Thasildar



Residence proof : years of living in the city.



MIS entry

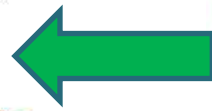

All documents available verified

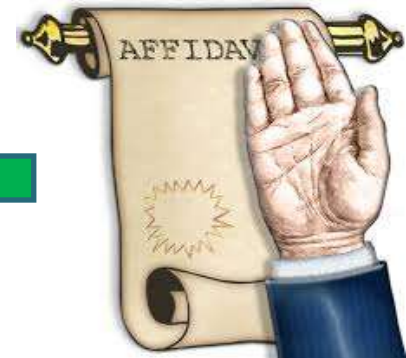
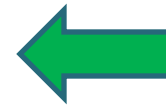

Affidavit : donot have pucca house any where in India, agreeing to pay my contribution



Stage -II: Authentication of Beneficiaries



List is placed in the ward for public, ward sabha conducted, resolution passed, signed by Councillor, ULB officer some beneficiary.



Addition and deduction of beneficiaries based on ward sabha and public display of name



Submit to ULB for review and finalization



Final list placed for approval



Authenticated by DUHS



Final list passed in the Council meeting



Display in the ULB flex board for public display and avoid wrong beneficiary

Legal/ disciplinary action will be taken on officials if wrong info is submitted

Stages of Disbursement of Fund

Estimated unit cost Rs 3,00,000/-

Share types		All figures in INR					TOTAL
		Plinth Level (P.L.)	Lintel Level (L.L.)	Roof Level (R.L.)	Roof Casting (R.C.)	Completed (includes toilet, electricity)	
ACA	Amount	-	60,000.00	40,000.00	25,000.00	25,000.00	1,50,000.00 (50%)
	%	0%	20%	13%	8%	8%	
State Share	Amount	-	15,000.00	15,000.00	10,000.00	10,000.00	50,000.00 (17%)
	%	0%	5%	5%	3%	3%	
Beneficiary Contribution	Amount	60,000.00	10,000.00	10,000.00	10,000.00	10,000.00	1,00,000.00 (33%)
	%	20%	3%	3%	3%	3%	
TOTAL		60,000.00	85,000.00	65,000.00	45,000.00	45,000.00	3,00,000.00

Flowchart of the process for uploading, retrieval, approval of Beneficiary and release of State Share and ACA to the beneficiary A/C

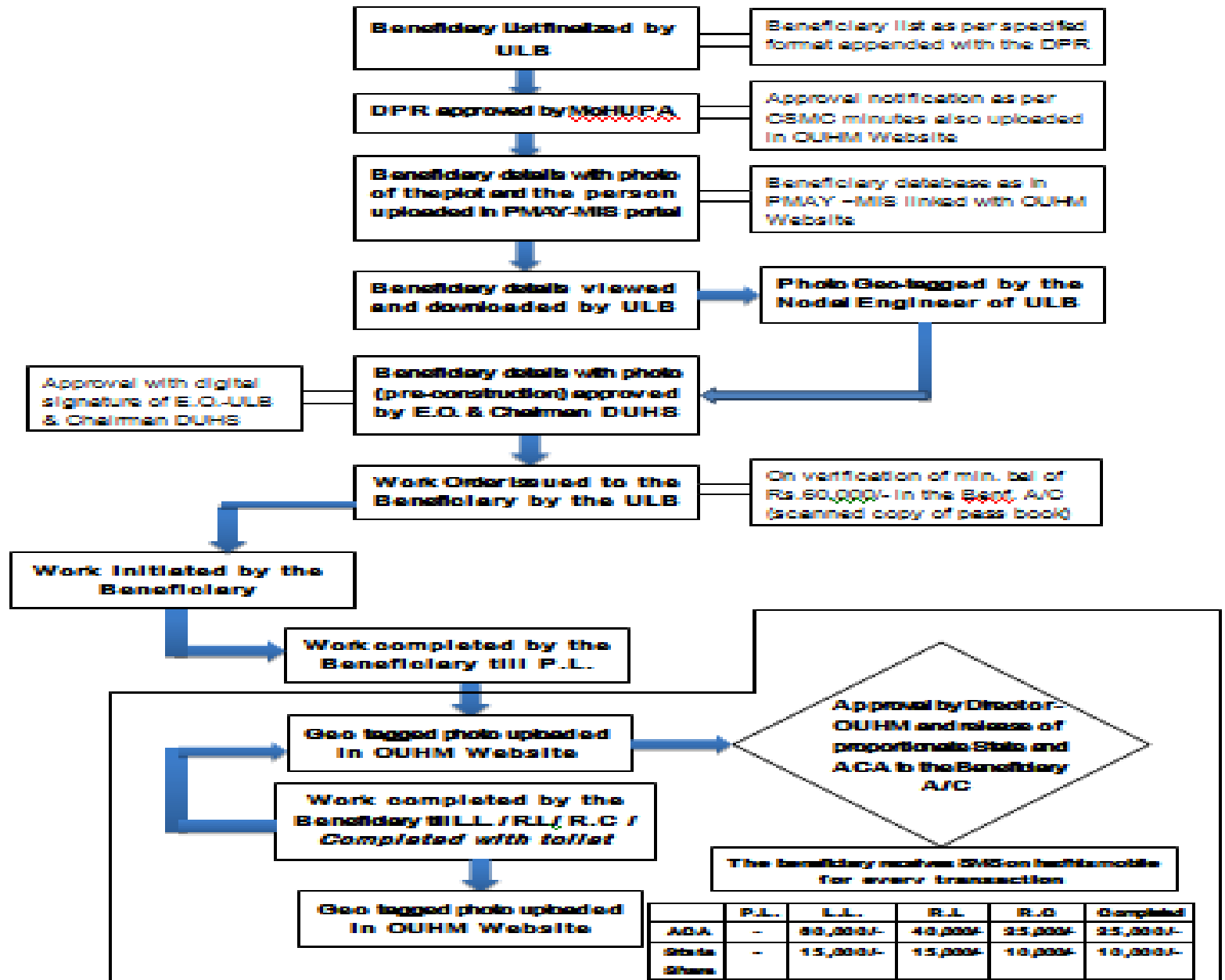

	P.L.	L.L.	R.L	R.O	Completed
ACA	-	80,000/-	40,000/-	25,000/-	25,000/-
State Share	-	15,000/-	15,000/-	10,000/-	10,000/-



Projects proposed for Approval

ADHERENCE TO THE CONDITIONS: **Against the projects placed for approval.**

Sl. No	Condition	Adherence
1	All proposed projects are on litigation free land?	Yes under BLC each beneficiary have their own RoR.
2	Status of Demand Survey, and timeline for completion, if not completed yet	Under progress will be completed by 30th July,2016.
3	If Demand Survey is complete, has the state shared the list of CLSS beneficiaries to the Ministry?	Demand survey under progress.
4	In case of In-Situ and BLC projects, whether beneficiaries have been identified and listed in the DPR along with their AHL-TIN from SECC data?	Yes, beneficiary selection has been done under each proposed project. However, the AHL-TIN SECC are being linked.
5	Timelines for Project Completion (Months) For all BLC Projects timelines must be within 2 years of release of funds from Government of India.	Yes, 12 months for BLC projects
6	Status of Physical Infrastructure like drainage, road, street lighting, solid waste management, etc? If not available, whether the provision has been made in the project on this account?	The project is linked with existing infrastructure and in some ULBs the infrastructure is taken care by the UIB/ State Share. Every ULBs have mandatorily reserved 25% of the total budget for Basic services to urban Poor. This fund will be utilised in providing basic infrastructures. Further provisions are also done under 14th FC towards infrastructure.
7	Whether the DPR mentions convergence with other centrally assisted programmes for provision of Infrastructure?	Yes, in some ULBs with Swachh Bharat Mission and AMRUT.

ADHERENCE TO THE CONDITIONS - Contd.....

Sl. No	Condition	Adherence
8	Whether connection to Electricity & Water Supply has been planned under the project? The project shall not be considered complete unless the Houses are provided with Electricity & Water Supply	Yes all the dwelling units will be provided with individual toilets, water connection and electricity.
9	Status of Social Infrastructure?	Existing in the proposed areas.
10	Beneficiary details compiled as per Annexure 4A/ 4B?	Yes.
11	Project Proposals submitted as per Annexure 7A/7B/7C?	Yes.
12	Whether the DPR contains the Financial details/Funding pattern of the Project?	Yes.
13	Details of the proposed ownership of houses – in favor of Women/Joint ownership	Ownership will be in the name of the existing RoR.
14	Any other innovative approach taken by the state in proposed projects?	Beneficiaries who will go rain water harvesting will be incentivized by the State.
15	Whether the Project Proposals are consistent and adhere to Guidelines in all aspects?	Yes.

Adherence to Conditions: BLC projects

I	Conditions for BLC	Adherence
	Whether the Beneficiaries have right-full ownership of land?	Yes
	Ready-ness of the State for geo-tagging of BLC Houses?	Under process of selection of agency for geo-tagging.
	Mechanism for Direct Benefit Transfer? (DBT)	State is in the final stage of developing an app for DBT through a Bank. This will be launched by 30th July,2016

Proposed Designs under BLC Vert - I

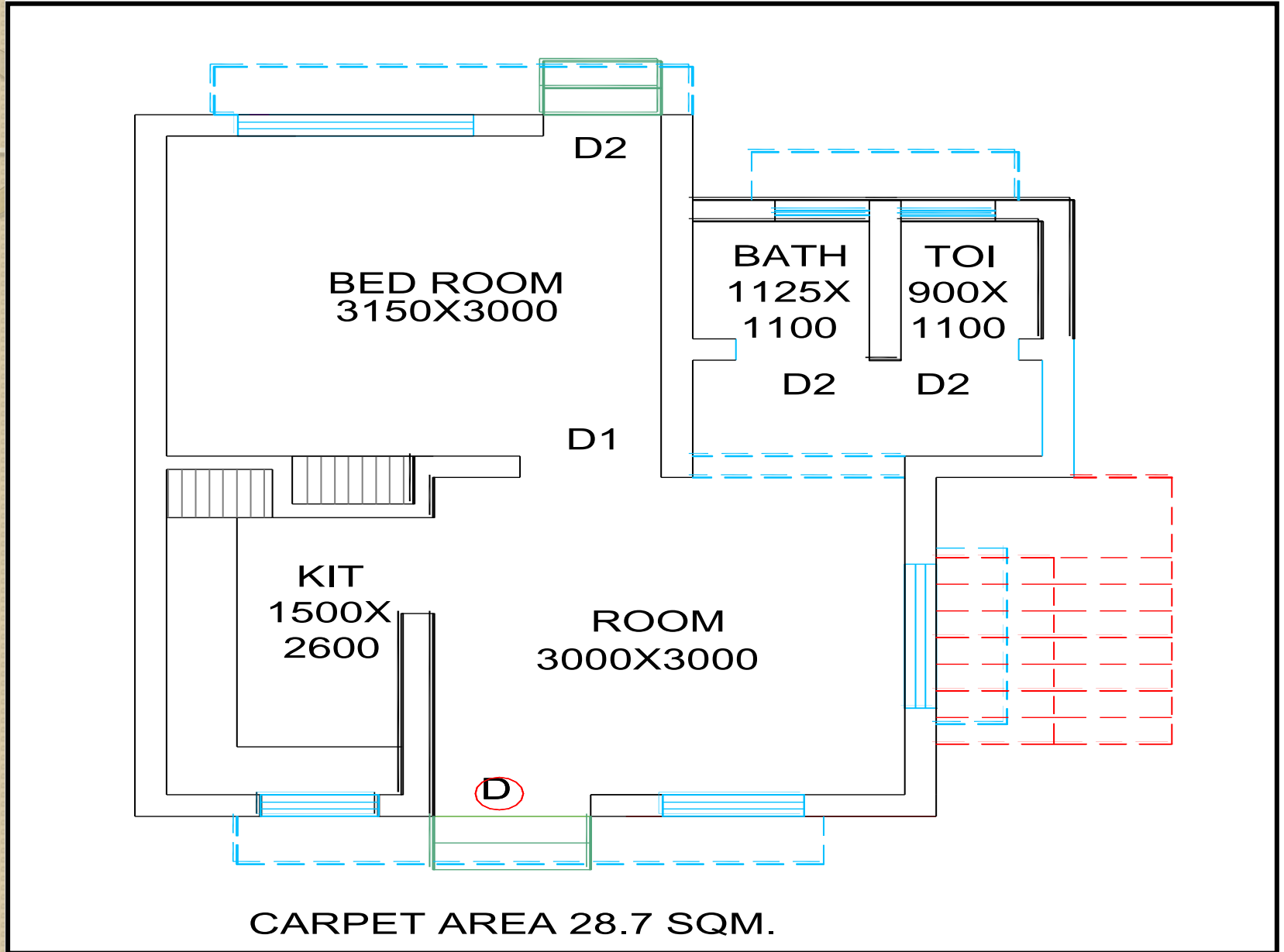

Proposed Designs under BLC Vert - II

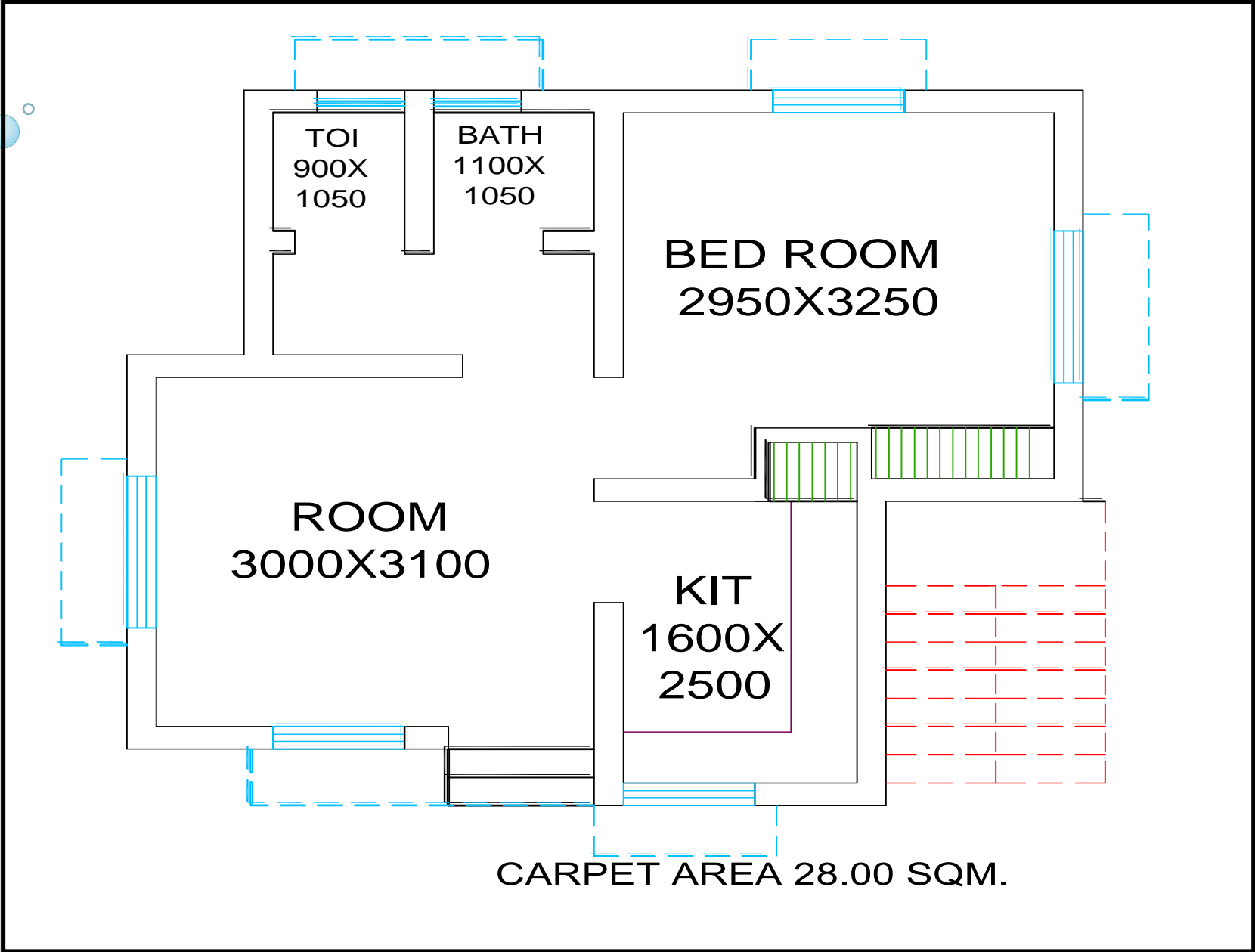

Proposed Designs under BLC Vert - III

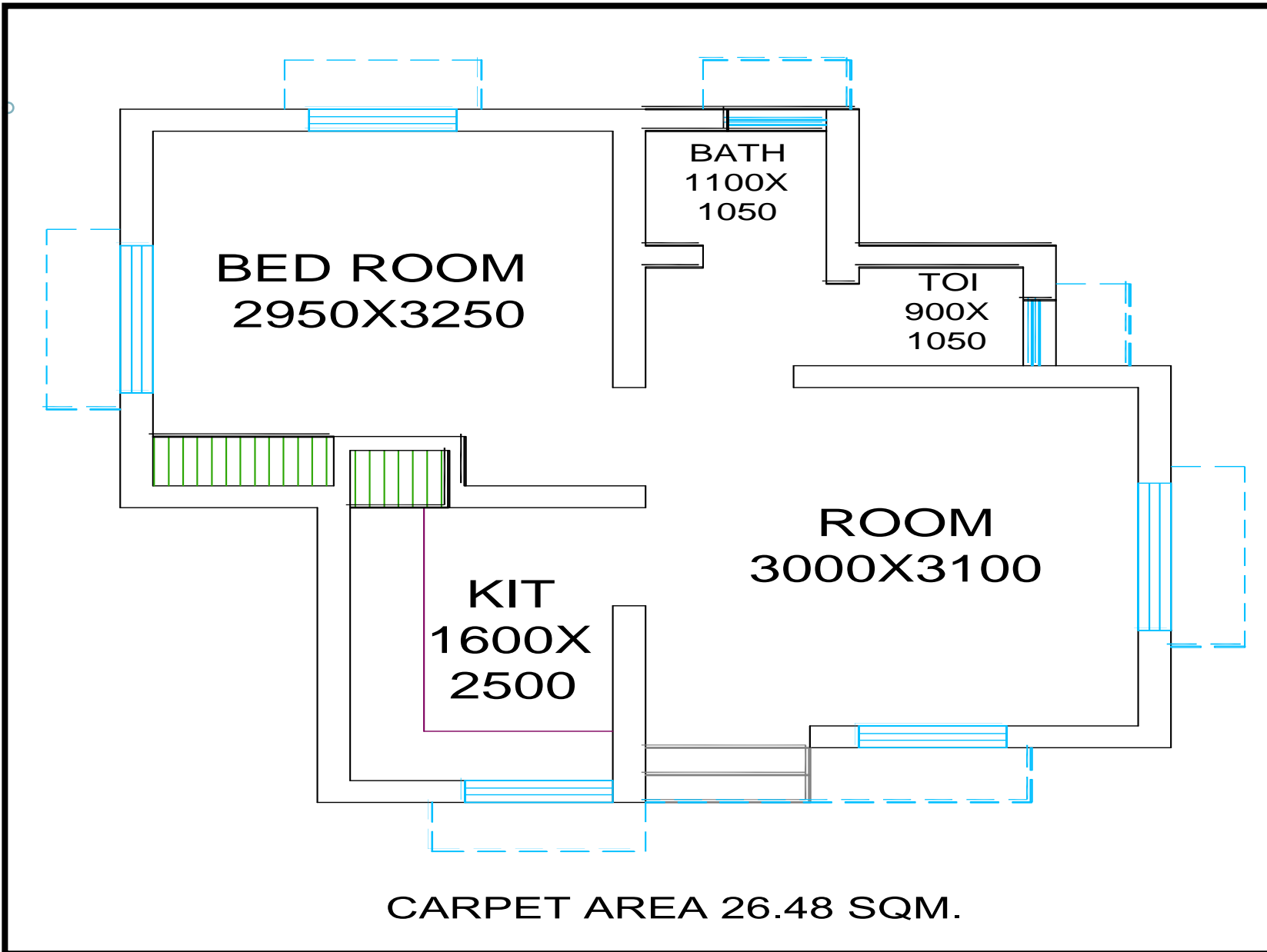

Structural Design

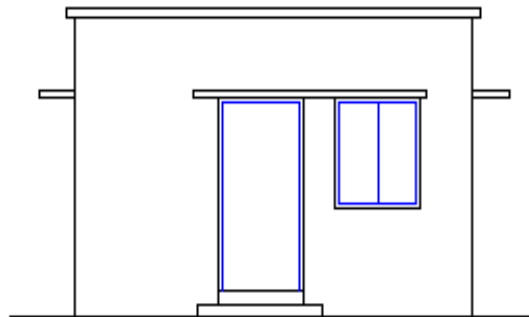

ELEVATION

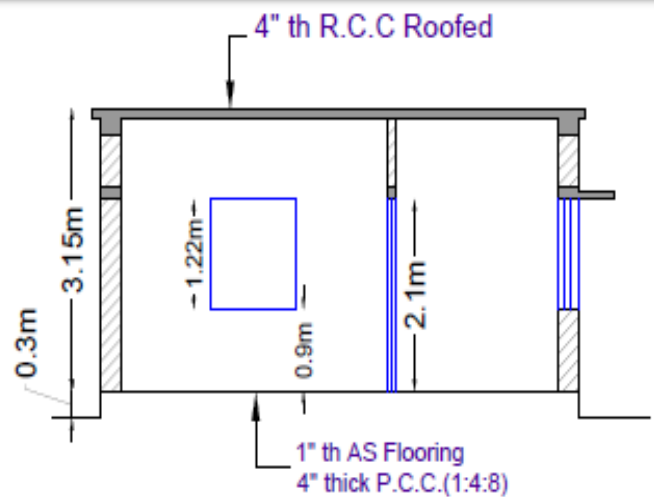

SECTION ON XX

- D- 1.05m x 2.1m
- D1- 0.75m x 2.1m
- W- 1.05m x 1.22m
- V- 0.625m x 0.625m

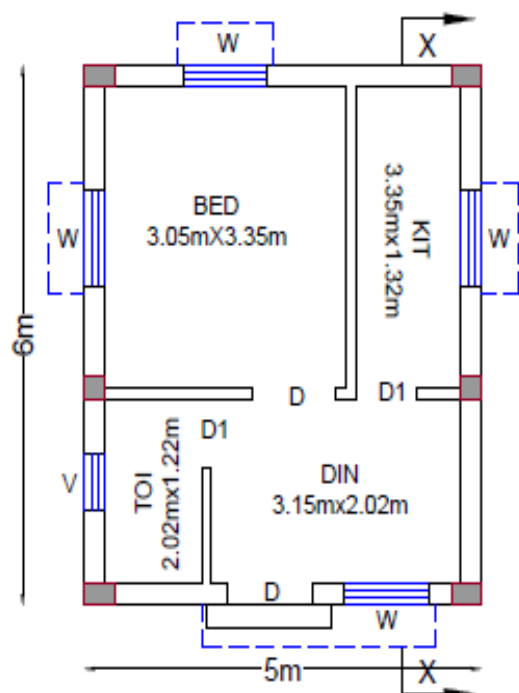

PLAN

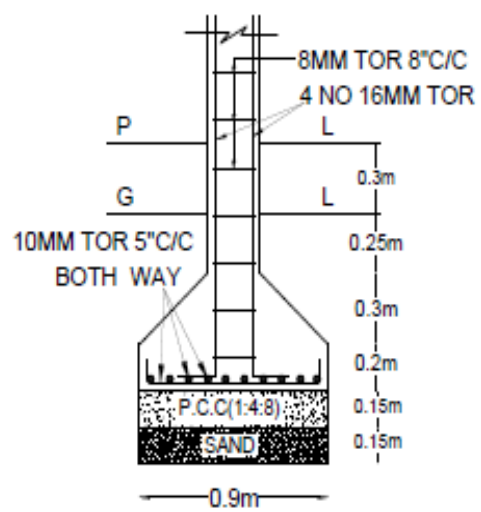

COLUMN FOUNDATION

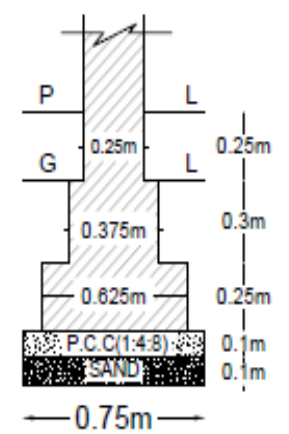

FOUNDATION

DWELLING UNIT



DWELLING UNIT WITH STAIRCASE FOR FUTURE VERTICAL EXPANSION



Beneficiary-led Construction at a Glance for approval

No of Cities / Projects	40 /41
Total EWS Houses proposed	23843
Gol Grant per EWS	1.5 lakhs
Total Gol Grant	35866.5lakhs
State Share @ 50,000 per unit	11955.5 lakhs
ULB Share	601.82 lakhs
Beneficiary Share	29827.59 lakhs
Other Charges	0.00
Total Project Cost	71913.83 lakhs

Project Details of Odisha under BLC

(Rs. In Lakhs)

Sl No	ULB Name	Project Cost	Gol Grant	State Grant	ULB Share	Beneficiary Share	Unit Cost	Rs.@ Beneficiary	No of DUs proposed
1	Bhubaneswar	11187	5593.5	1864.5	0	3729	3	1	3729
2	Cuttack	6775.86	3066	1022	643.86	2044	3.32	1	2044
3	Jajpur	2998.35	1650	550	358.35	440	2.73	0.4	1100
4	Baripada	3300	1650	550	0	1100	3	1	1100
5	Vyasangar	3290.98	1648.5	549.5	0	1092.98	2.99	0.99	1099
6	Berhampur	2503.16	1438.5	479.5	0	585.16	2.61	0.61	959
7	Jagatsinghpur	2364	1182	394	0	788	3	1	788
8	Dhenkanal	1956	978	326	0	652	3	1	652
9	Basudevpur	2037.63	976.5	325.5	0	735.63	3.13	1.13	651

Project Details of Odisha under BLC

(Rs. In Lakhs)

SI No	ULB Name	Project Cost	GoI Grant	State Grant	ULB Share	Beneficiary Share	Unit Cost	Rs.@ Beneficiary	No of DUs proposed
10	Sundargarh	2255.5	975	325	0	955.5	3.47	1.47	650
11	Talcher	1951.11	967.5	322.5	177.36	483.75	2.75	0.75	645
12	Phulbani	1860.04	955.5	318.5	0	586.04	2.92	0.92	637
13	Rayagada	1800	900	300	0	600	3	1	600
14	Jharsuguda	1500	750	250	0	500	3	1	500
15	Sambalpur	1475	750	250	0	475	2.45	0.95	500
16	Bargarh	1735	750	250	0	735	3.47	1.47	500
17	Bhawanipatna	1611.15	700.5	233.5	0	677.15	3.45	1.45	467
18	Paradeep	1362.77	688.5	229.5	0	444.77	2.97	0.97	459

Project Details of Odisha under BLC

(Rs. In Lakhs)

Sl No	ULB Name	Project Cost	Gol Grant	State Grant	ULB Share	Beneficiary Share	Unit Cost	Rs.@ Beneficiary	No of DUs proposed
19	Sunabeda	1400.84	675	225	127.34	373.5	2.33	0.83	450
20	Keonjhar	1583.3	669	223	0	691.3	3.55	1.55	446
21	Baleswar	1200	600	200	0	400	2.5	1	400
22	Umerkote	1290.3	586.5	195.5	0	508.3	3.3	1.3	391
23	Chaudwar	1708.99	583.5	194.5	541.99	389	2.5	1	389
24	Puri	1150.27	568.5	189.5	0	392.27	3.04	1.04	379
25	Sunabeda Ph-II	1007.48	534	178	0	295.48	2.83	0.83	356
26	Rajgangapur	1125.07	490.5	163.5	0.19	470.88	3.44	1.44	327
27	Brajarajnagar	988.68	481.5	160.5	89.88	256.8	2.3	0.8	321

Project Details of Odisha under BLC

(Rs. In Lakhs)

SI No	ULB Name	Project Cost	Gol Grant	State Grant	ULB Share	Beneficiary Share	Unit Cost	Rs.@ Beneficiary	No of DUs proposed
28	Rourkela	1279.72	430.5	143.5	424.46	281.26	2.98	0.98	287
29	Pattamundai	797.533	394.5	131.5	8.53	263	3	1	263
30	Joda	792.54	388.5	129.5	0	274.54	3.06	1.06	259
31	Angul	599.04	384	128	0	87.04	2.34	0.34	256
32	Soro	768	384	128	0	256	3	1	256
33	Barbil	756	378	126	0	252	3	1	252
34	Jaleswar	756	378	126	0	252	3	1	252
35	Bhadrak	750	375	125	0	250	3	1	250
36	Deogarh	675	375	125	0	175	2.7	0.7	250

Project Details of Odisha under BLC

(Rs. In Lakhs)

Sl No	ULB Name	Project Cost	Gol Grant	State Grant	ULB Share	Beneficiary Share	Unit Cost	Rs.@ Beneficiary	No of DUs proposed
37	Rairangpur	750	375	125	0	250	3	1	250
38	Biramitrapur	625	375	125	0	125	2.5	0.5	250
39	Malkanagiri	975.8	307.5	102.5	0	565.8	4.76	2.76	205
40	Paralakhemundi	561	280.5	93.5	0	187	3	1	187
41	Titlagarh	261	130.5	43.5	0	87	3	1	87
TOTAL		74,918.70	36337.50	12112.50	2371.96	24096.74			23843

Status of Housing Covered Against Housing Shortage in proposed 40 ULBs

Sl No	Name of the ULB	Total Household	Total Housing Shortage	Proposed under BLC-PMAY	Covered under AHP-PMAY	Covered under In Situ - PMAY	Covered under Other Housing Scheme (IHSDP,BSUP, Ray)	Total Demand covered	% of demand covered	No of housing yet to be covered	% to be covered
1	2	3	4	5	6	7	8	9	10	11	12
1	Bhubaneswar	2,11,609	68,702	3,729	5,548	1,200	5,637	16,114	23.45	52,588	76.55
2	Rourkela	1,05,262	40,103	287	-	4,800	124	5,211	12.99	34,892	87.01
3	Puri	42,740	34,461	379	-	-	217	596	1.73	33,865	98.27
4	Cuttack	1,05,223	24,240	2,044	-	-	1,058	3,102	12.80	21,138	87.20
5	Paradeep	18,579	18,846	459	-	-	-	459	2.44	18,387	97.56
6	Bhadrak	19,763	17,679	250	-	-	218	468	2.65	17,211	97.35
7	Sambalpur	54,142	17,454	500	-	-	613	1,113	6.38	16,341	93.62
8	Jharsuguda	19,414	16,161	500	-	-	786	1,286	7.96	14,875	92.04
9	Bhawanipatna	14,588	12,933	467	-	-	164	631	4.88	12,302	95.12
10	Baripada	22,976	12,556	1,100	-	-	321	1,421	11.32	11,135	88.68
11	Brajarajnagar	17,322	12,066	321	-	-	177	498	4.13	11,568	95.87
12	Barbil	13,418	11,341	252	-	-	-	252	2.22	11,089	97.78
13	Bargarh	16,429	10,991	500	-	-	732	1,232	11.21	9,759	88.79
14	Berhampur	64,646	10,719	959	-	-	5,602	6,561	61.21	4,158	38.79
15	Balasore	23,741	10,715	400	-	-	549	949	8.86	9,766	91.14
16	Basudevpur	7,056	10,115	651	-	-	-	651	6.44	9,464	93.56
17	Patamundai	7,344	8,077	263	-	-	-	263	3.26	7,814	96.74
18	Soro	6,638	7,613	256	-	-	-	256	3.36	7,357	96.64
19	Keonjhar	11,802	7,197	446	-	-	261	707	9.82	6,490	90.18
20	Biramitrapur	6,810	6,961	250	-	-	200	450	6.46	6,511	93.54

Cont.....

Status of Housing Covered Against Housing Shortage in proposed 40 ULBs

Sl No	Name of the ULB	Total Household	Total Housing Shortage	Proposed under BLC-PMAY	Covered under AHP-PMAY	Covered under In Situ - PMAY	Covered under Other Housing Scheme (IHSDP,BSUP, Ray)	Total Demand covered	% of demand covered	No of housing yet to be covered	% to be covered
1	2	3	4	5	6	7	8	9	10	11	12
21	Rajgangpur	10,503	6,475	327	-	-	-	327	5.05	6,148	94.95
22	Titilagarh	6,862	6,422	87	-	-	-	87	1.35	6,335	98.65
23	Jajpur	7,908	6,245	1,100	-	-	1,996	3,096	49.58	3,149	50.42
24	Joda	8,335	6,207	259	-	-	174	433	6.98	5,774	93.02
25	Vyasnagar	9,853	6,133	1,099	-	-	1,016	2,115	34.49	4,018	65.51
26	Dhenkanal	13,527	6,050	652	-	-	608	1,260	20.83	4,790	79.17
27	Umerkote	6,255	5,667	391	-	-	-	391	6.90	5,276	93.10
28	Sundargarh	9,417	5,663	650	-	-	-	650	11.48	5,013	88.52
29	Raygada	14,878	5,274	600	-	-	-	600	11.38	4,674	88.62
30	Deogarh	4,877	5,134	250	-	-	-	250	4.87	4,884	95.13
31	Choudwar	8,520	4,818	389	-	-	-	389	8.07	4,429	91.93
32	Malkanagiri	6,520	4,754	205	-	-	236	441	9.28	4,313	90.72
33	Jagatsinghpur	6,799	4,604	788	-	-	162	950	20.63	3,654	79.37
34	Jaleswar	5,362	4,408	252	-	-	-	252	5.72	4,156	94.28
35	Rairangapur	5,160	4,034	250	-	-	-	250	6.20	3,784	93.80
36	Phulbani	7,829	3,928	637	-	-	157	794	20.21	3,134	79.79
37	Talcher	8,145	3,735	645	-	-	155	800	21.42	2,935	78.58
38	Angul	8,325	3,320	256	-	-	334	590	17.77	2,730	82.23
39	Parlakhemundi	9,518	2,827	187	-	-	307	494	17.47	2,333	82.53
40	Sunabeda	12,151	2,334	806	-	-	-	806	34.53	1,528	65.47
		9,60,246	4,56,962	23,843	5,548	6,000	21,804	57,195	12.52	3,99,767	87.48

Total housing shortage and housing covered under various schemes

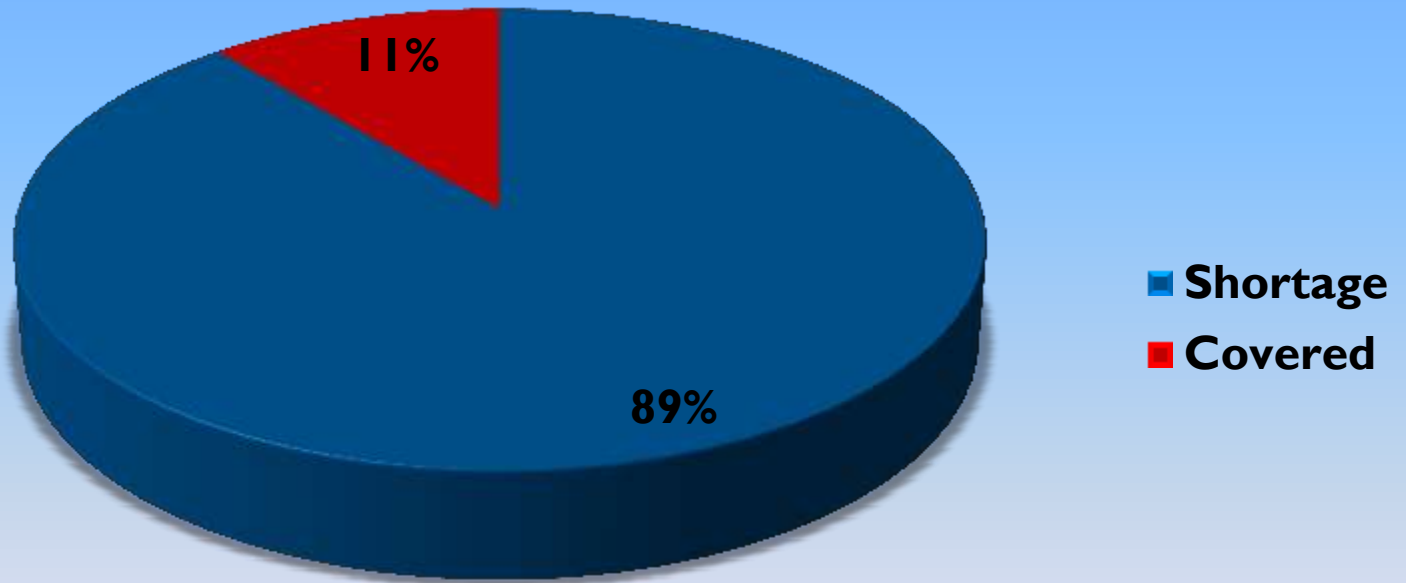

Proposal for setting up of SLTC and CLTC

- **CB Plan 2015-16 submitted by Odisha had proposed for setting up of SLTC with 8 Specialist and 18 cluster based CLTC with 72 professionals.**
- **Meanwhile, Odisha State has come with establishment of District Urban Housing Societies(DUHS) in each Districts and one at Bhubaneswar.**
- **Given this backdrop, it is proposed to setup 31 cluster based CLTCs with 4 professional i.e. 124 professionals**
- **And 10 professionals instead of 8 at SLTC.**
- **ASCI has been selected on nomination basis for establishment of SLTC and CLTC along with other deliverables like preparation of HFAPoA, AIP, conducting workshops & trainings, Exposure visits as per the GoI approved rates.**
- **The Proposal has been approved by SLSMC held on 25th June,2016 under the Chairmanship of Chief Secretary.**
- **Submitted for kind approval of CSMC**

Status of Affordable Housing Projects of Bhubaneswar approved in the CSMC held on 21st December,2015

Sl. No.	Name of Project	Status
1.	Affordable Housing at Ghatikia	<ul style="list-style-type: none">• Sub-judice in High Court over tendering issue.
2.	Affordable Housing at Chandra-sekharapur	<ul style="list-style-type: none">• Sub-judice in High Court over tendering issue,
3.	Affordable Housing at Nakhara	<ul style="list-style-type: none">• Sub-judice in High Court over tendering issue
4.	Affordable Housing at Pandara	<ul style="list-style-type: none">• Sub-judice in High Court over tendering issue

In-Situ Slum Redevelopment Project approved by CSMC on 17th March,2016

PMAY – In situ- (Bhubaneswar & Rourkela)

01	Name of the Project	:	Pradhan Mantri Awas Yojana (PMAY)
02	No. of Projects	:	02 Nos. under In-situ Slum Redevelopment (Bhubaneswar & Rourkela)
02	No. of Towns/Cities Covered	:	02 Nos.
03	Total Project Cost	:	Rs. 342.29 Cr
04	Total GoI Grant	:	Rs. 60.00 Cr.
05	Total State / PPP Partner	:	Rs. 192.29 Cr.
06	Total Beneficiary share	:	Rs. 90.00Cr.
10	Total EWS DUs proposed	:	6000 Nos.
11	<u>Present Status</u>	:	Rourkela: RFP for selection of TA for Rourkela Project will be floated on 25 th July,2016 Bhubaneswar: RFP for selection of PPP partner has been floated on 14 th July,2016. Transit Accommodations completed, infrastructure under progress will be completed by September,2016

Transit houses for beneficiaries (920 units)

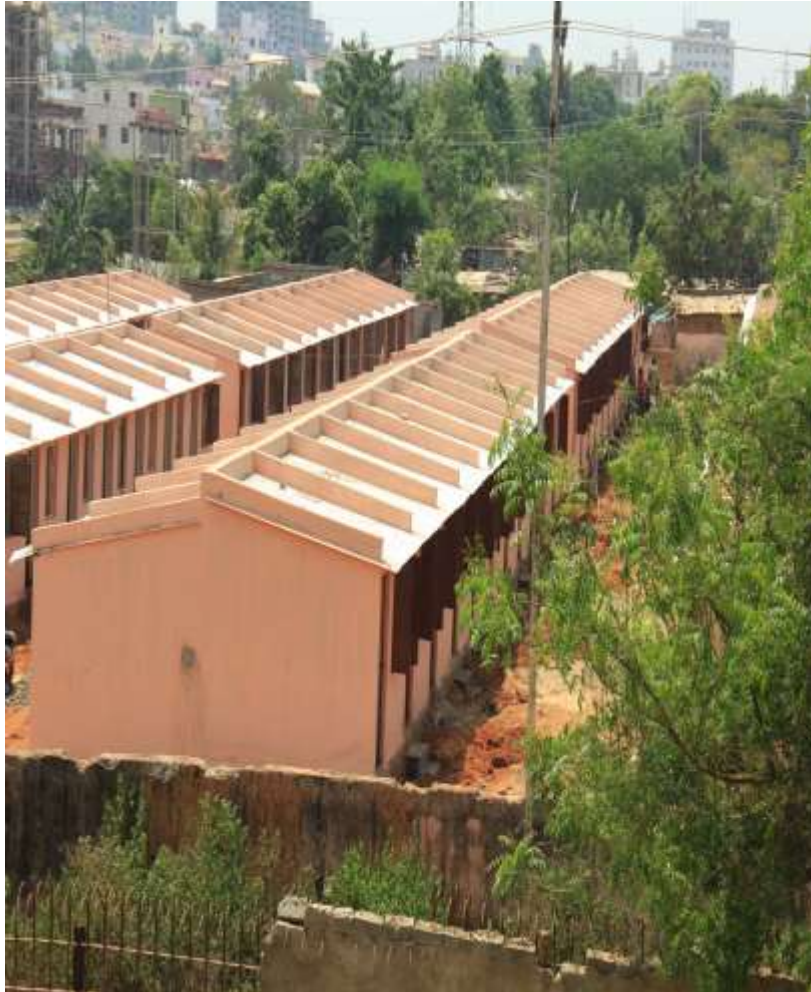

Status of Old Schemes

Name of scheme	No. of projects approved	No. of DUs approved	No. of DUs completed	No. of DUs Occupied	No. of DU under Progress	No of DUs surrendered	Time line given for completion of projects
1	2	3	4	5	6	7	8
BSUP	6	2081	1634	1634	202	427	Oct,2016
IHSDP	38	12742	9785	9785	2957	355	Oct,2016
RAY	16	11235	402	266	2796	00	March,2017



THANK YOU...



BHULAKH

LAND RECORDS WEB PORTAL OF ODISHA



Schedule I Form No.39-A

ଖରିଦାନ

ଶୀଳ : ବାବୁ

ଥାନ : ବିଖିଳି

ଥାନ ନମ୍ବର : 14

ଦେସିକ : ବିଖିଳିବାବୁ

ଦେସିକ ନମ୍ବର : 12

ବିଭା : ଖମ୍ବାନ

କମିସନର ନାମ ଓ ଖେତ୍ର ବା ଖରିଦାକର କ୍ରମିକ ନମ୍ବର		ଓଡ଼ିଶା ସରକାର ଖେତ୍ର ନମ୍ବର 1				
1) ଖରିଦାକର କ୍ରମିକ ନମ୍ବର		104				
2) ପ୍ରକାର ନାମ, ପିତାଙ୍କ ନାମ, ଜାତି ଓ ବାସସ୍ଥାନ		ଯେତ୍ରୁ ସାହୁ ପି : ବାଉରି ସାହୁ ବା: ଚନ୍ଦ୍ରଶି ବା: ମିଶ୍ରଣୀ				
3) ମୂଲ୍ୟ	ଘରବାରି					
4) ଦେଇ :	କମର	ଖଜଣା	ସେଫ୍	ନିଷ୍କାର ସେଫ୍ ଓ ଅନ୍ୟାନ୍ୟ ସେଫ୍ ଯଦି କିଛି ଥାଏ	ଟୋଟା	5) କ୍ରମବର୍ଦ୍ଧନାତ୍ମକ ଖଜଣାର ବିବରଣୀ
		4.60	1.15		5.75	
6) ବିଶେଷ ଅନୁସଙ୍ଗ ଯଦି କିଛି ଥାଏ		ଏହି କମିସନର ଯୋଗ୍ୟ ନୁହେଁ				
BLANK SPACE FOR STAMPING						
ଅନ୍ତିମ ପ୍ରକାଶନ ତାରିଖ - 31/05/1977						
ଖଜଣା ଧାରଣ ତାରିଖ - 04/01/1977						